

Installation & user manual

Fire extinguishing

FIRE MERMAID X1

Rev.24-09-99 / Rev.id.: MK 1 / File: 528360 Installationsmanual-Pyrogen -UK A5.doc



Pyrogen Ltd.

Gilnow Mill Business Centre,
Spa Road, Bolton. BL1 4LF (U.K.)

Telephone: +44 (0)1204 373300

fax: +44 (0)1204 373355

E-mail: purogen@btconnect.com

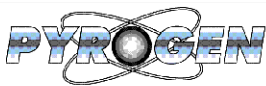

FIRE MERMAID X1



Contents

1. User instructions	5
Fire	5
When a fire in the engine room is discovered:	5
Alarm	5
When an alarm appears on the control panel:.....	5
Fault	5
When a fault occurs:.....	5
Alarms	6
Fire <u>flashes</u> , horn is <u>pulsating</u> (beacon <u>flashes</u>).....	6
Fire <u>flashes</u> , fault and horn is <u>continuous</u> (beacon is <u>contin.</u>)	6
Fault <u>lights</u> , horn <u>pulses</u> (beacon <u>flashes</u>)	6
Functions description	7
Fire.....	7
Fault.....	7
After discharge.....	7
2. Main system components	8
General.....	8
The Pyrogen canister	8
contents	8
Fire extinguishing.....	9
The control panel	9
Fire Mermaid X1.....	9
Monitoring	10
Start	10
3. Service.....	11
General.....	11
The regular visual inspection should include that:.....	11
10 year service.....	11
After discharge	12
Recommended procedure for replacement	12
Disposal	12
Notes	12
4. Installation.....	13
General.....	13
Installation procedure	14
Material:	14
Tools:.....	14
Order of connection	14
Control panel mounting.....	15
Pyrogen canister mounting	15
The control panel	16
General	16
Connections.....	17

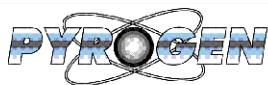

FIRE MERMAID X1

Settings (programming)	17
Auxiliaries	18
Sensor cable	18
The Pyrogen canister	19
5. Trouble shooting	20
No light in the control panel	20
Fault is lit	21
Fire is lit	22
External alarms	23
General	23
Connected to "Sounder" or "Light/Beacon"	23
Connected to the Fault/Fire terminals	23
6. Accessories and spare parts	24
Kits	24
Included in the kit	24
Accessories	24
Spare parts	25
7. Pyrogen safety data	27
Limitations	27
Visibility	28
Oxygen levels	28
Toxicity	28
Post fire exposure	29
Thermal hazard	29
Hot work	29
Re-entry	29
Clean-up	30
Dangerous good classification	30
CoSHH statement	30
Noise	30
8. Technical specification	31
9. Fire procedure	32
10. Commissioning check list	33
11. Service log	34
12. Installation templates	37
Control panel	37
Pyrogen canister mount	39

Observe safety information in chapter 7 (page 27)

1. User instructions

Fire

When a fire in the engine room is discovered:

- 1. Check that the engine room has been evacuated.**
- 2. Close the engine room hatches.**
- 3. Press both discharge buttons simultaneously for 5 sec.**
- 4. Turn off the engine.**
- 5. Disconnect all power supplies (EI/gas/fuel).**
- 6. Perform a role call.**
- 7. Check that everybody is present and unhurt.**
- 8. Verify that the fire is extinguished. (only open the hatches slightly. Caution must be used not to become exposed to the fire or its bi-products)**
- 9. Repair/mend the cause of the fire.**

Alarm

When an alarm appears on the control panel:

- 1. Check if it is a fire or a fault alarm.**
- 2. If it is a fire see above "Fire".**
- 3. If it is a fault see below "Fault".**

Fault

When a fault occurs:

- 1. Disconnect all power to the control panel**
- 2. Disconnect the Pyrogen canister.**
- 3. Find the fault and repair it.**
- 4. Re connect the power supply**
- 5. Reconnect the Pyrogen canister**
- 6. Verify that the fault alarm does not reappear.**

Alarms

Fire = Flashing light and puls. sound (and beacon).

Discharge = Continuous light and cont. sound (and beacon).

Fault = Continuous light and puls. sound (and beacon).

Fire flashes, horn is pulsating (beacon flashes)

Fire alarm

When both discharge buttons are activated, or the sensor cable has melted (burned), the fire extinguisher will discharge after app. 5 sec warning.

In the event of an automatic alarm it should be verified immediately, to check if it is a fire, or what is the cause for the alarm. The sounder (and beacon) can be turned off by pressing the button "Reset sound", the alarm will still be active and discharge the fire extinguisher app. 5 seconds after the alarm started.

Fire flashes, fault and horn is continuos (beacon is contin.)

Fire extinguishing

When the fire extinguisher has been discharged, the horn and beacon can be turned off by pressing the "Reset sound" button. Fire and fault will still be on at the control panel until the sensor cable and the fire extinguishers are replaced.

If the fire extinguishing was activated by the sensor cable the fire light in the control panel will remain lit until the sensor cable has been replaced/disconnected. If the sensor cable is disconnected fault will be indicated on the control panel until the sensor cable is replaced/reconnected.

Fault lights, horn pulses (beacon flashes)

Fault

If fault is lit and no other indications are lit a fault has occurred on the system, see next page.

Functions description

Fire

When the sensor cable is shorted (this happens at 105°C) the control panel will indicate fire (see previous page). If the two discharge buttons "DISCHARGE" on the front of the control panel are activated simultaneously a fire will also be indicated. After 5 sec. of warning the fire extinguisher is activated. The relay fault/Fire (port 10 + 11) will operate whether or not jumper J2 is installed (see page 17).

During a fire indication the light and sound is pulsating/flashing. When the fire extinguisher is activated beacon and sound will shift to continuous.

When the fire extinguisher is activated a fault indication will appear (see below)

If the sounder is reset manually (by pushing the button "Reset sound") the sounder and beacon will be turned off.

Fault

When a fault occurs on the system the control panel will indicate fault (see previous page).

The relay Fault/Fire (port 10 +11) will change if jumper J2 is installed. If J2 is not installed the relay will not operate (if the relay is used to control ventilation in the engine room it is not desirable to have the ventilation stopped due to a fault, it should only be stopped in case of a fire).

After discharge

When the system has discharged it will not function until it has been re-installed. The Pyrogen unit must be replaced.

See the chapter "Service" and "after discharge"

2. Main system components

General

Fire Mermaid X1 is designed to control fire extinguishing systems in boats. The extinguishing system is Pyrogen. Pyrogen canisters are activated directly by an electrical impulse.

The Pyrogen canister

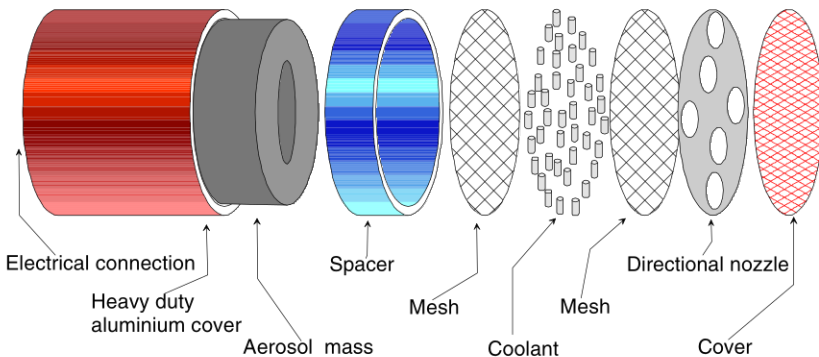

contents

The aerosol generating chemical is a thermoplastic mixture consisting of an oxidiser, a combustible binder and additives. The oxidiser is solid potassium nitrate (KNO_3), the binder is solid plasticised nitro-cellulose ($\text{C}_n\text{H}_m\text{N}_p\text{O}_q$) and other ingredients for stabilisation.

Combustion products consists of potassium carbonate (KHCO_3 , K_2CO_3), carbon dioxide (CO_2), nitrogen (N_2) and water (H_2O) and represent the actual extinguishing agent, completely environmental friendly.

Fire extinguishing

Pyrogen is mainly potassium carbonate formed in the gas phase. It condenses to a liquid and then a solid form producing a large number of micron sized particles. Being so small, the particles produce a large surface area increasing the efficiency. (Potassium carbonate is similar to the powder in dry powder extinguishers).

The micron sized aerosol particles exhibit a gas like 3-dimensional quality that allow the agent to rapidly distribute throughout enclosure and reach the most concealed and shields location.

The typical design factor (when dimensions of room/MAG is kept within limits stated in this manual) is 100 g/m³.

The control panel

Fire Mermaid X1



The Fire Mermaid X1 is a compact control panel which can be fitted to any boat. The Fire Mermaid X1 is easily installed and offer a high class finish to the boats instrumentation. The panel is water proof when installed due to the high end membrane switches used in the all sealed front panel.



FIRE MERMAID X1

Monitoring

The detector loop is continuously monitored when the control panel is on. If the cable or detector are disconnected, a fault indication will appear. When the control panel is turned off the detector loop remains active. A fire will cause the control panel to come on and discharge the fire extinguisher (as long as the battery is connected).

The discharge loop is monitored. If connection to the fire extinguisher is disconnected a fault will also be indicated.

Start

When the ignition is switched on the control panel will perform a start up procedure. When the ignition has been on for app. 1½ minutes the control light "Ready" will be lit green on the control panel (it is not possible to discharge the fire extinguisher during the start-up procedure).

When the boat ignition is switched off the system can not be activated manually. The detector port is still active. If the detector port is shorted (the sensor cable shorts at 105 °C) the control panel will perform a auto start and activate the fire extinguisher after app. 15 sec. If the batteries are completely disconnected the control panel will not be able to perform the activation.

The sole purpose of having the control panel in standby is to save energy.

3. Service

General

- None.

Fire Mermaid X1 is a maintenance free system as it is self monitoring. The condition of wire connections, plugs and auxiliary equipment should be inspected visually on a regular basis in order to prevent damage and faults from occurring.

The Pyrogen canister works by a chemical process and therefore it has a limited life.

The regular visual inspection should include that:

- All wires are secured.
- No wires have poor isolation.
- All connections are clean and sealed.
- No moisture is present in connections and there is no corrosion.
- The Pyrogen canister is less than 10 years old.
- The Pyrogen canister is free from dents/markings or any damage.

10 year service

- Replace the Pyrogen canister.



FIRE MERMAID X1

After discharge

The Pyrogen canister must be replaced after discharge. If the fire extinguisher was activated by the sensor wire then it must be replaced too. (see the section *Pyrogen canister* and *sensor cable* in the chapter "Installation").

Recommended procedure for replacement.

1. Disconnect both power supplies to the control panel.
2. Disconnect the Pyrogen/actuator canister
3. Remove the Pyrogen canister from its brackets
4. Remove the old and install a new sensor cable
5. Install a new Pyrogen canister
(replace brackets if necessary)
6. Connect the wire plug to the Pyrogen canister
7. Connect power to the control panel.
8. Turn the ignition on
9. Verify that there are no fault indications on the panel

Disposal

Following activation the Pyrogen canister contains no harmful matter and may be disposed of by using conventional household refuse facilities. Alternatively some distributor may offer a financial incentive to return the old unit to them.

Notes

4. Installation

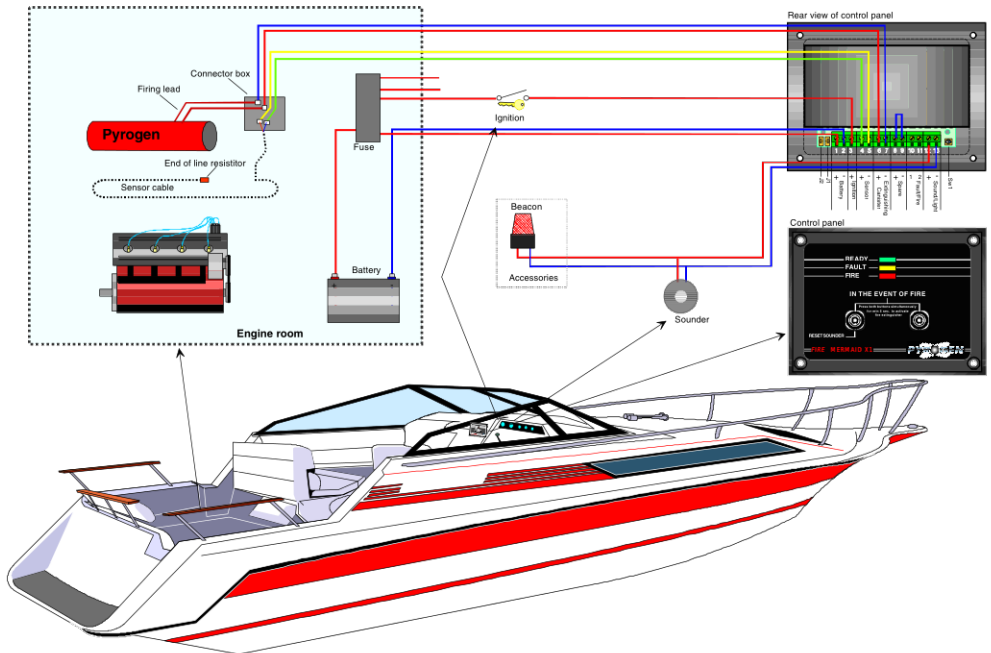

Wiring diagram of the *FIRE MERMAID X1* system

General

Before any work is started the motor must be stopped and the battery +ve terminal must be disconnected. Do not connect the battery terminal before the installation is completed. Prepare the installation very carefully, have all the right tools and material ready before the installation is started.

Warning:

The Pyrogen canister may be activated by exposure to flames and Heat. Avoid exposing the Pyrogen canister for elevated temperatures or direct sunlight.

Installation procedure

The below material must be available for installation.

Material:

1. Sufficient wire with an area of $>1 \text{ mm}^2$
Its recommended to use fire resistant wire (IEC 331).
2. Available outlet on the fuse box (min 2 Amp)
An suitable inline fuse may be used.

Tools:

1. #2 plain screw driver and PZ 1+2 screw driver
2. T20 Torx screwdriver
3. Drill with 3.0 & 10 mm drill bit
4. Electric jig saw

Order of connection

1. Turn off the engine and disconnect the battery +ve terminal
2. Mark the control panel cut out in the cockpit (see p.15)
3. Make the cut out for the control panel (see p. 15)
4. Install the sensor cable (see p. 18)
5. Install the Pyrogen canister (see p. 19)
6. Install the connection box in the vicinity of the engine room
7. Connect the sensor cable to the connection box (see p. 18)
8. Place Sw1 in the desired position (see p. 17)
9. Check the position of jumper J1 and J2 (see p. 17)
10. Install wires from the connector box to the control panel
11. Connect horn and optional beacon
12. Connect other auxiliary equipment (ventilation)
13. Connect the wires in the connection box
14. Connect the wires at the control panel
15. Connect wires from the ignition switch to the control panel
16. Connect the control panel to the fuse box (or inline fuse)
(see p. 17)
17. Connect the Pyrogen canister
18. Verify that all connections are correctly made
19. Reconnect the battery



Control panel mounting

- Cut out the template in the back of this manual by cutting along the grey line (100×130mm).
- Place the template on the dashboard in the cockpit, in the desired spot (it must be a place which is easy accessible) to which the access will not be limited in the event of a fire in the engine room. The template should be placed so that the diagonal lines, where the holes are to be drilled, is placed downward. Double sided sticky tape may be use to secure the template during installation.

The control panel must be easily accessible also in the event of an engine fire.

- Mark with a sharp pointer the 6 corners in the cut-out. Mark the centre of the 10 mm hole and the 4 screw holes as well.
- Drill a 10 mm hole in the bottom left corner.
- Use a jig saw to make the cut-out in the dashboard. The cut-out must follow the full black line on the template. To make sharp corners it may be necessary to cut from both sides. Use the correct jigsaw blade according to dashboard material.
- File off any rough edges, using a suitable file.
- Unwrap the control panel and verify that it will fit the cut-out without interfering with dashboard. Verify that the screw marks lie up as well.

Pyrogen canister mounting

An Ideal mounting would be right ion the bulkhead high up in the engine space pointing toward the engine. This way the Pyrogen will be distributed evenly over the engine which is the potential fire hazard.

The control panel

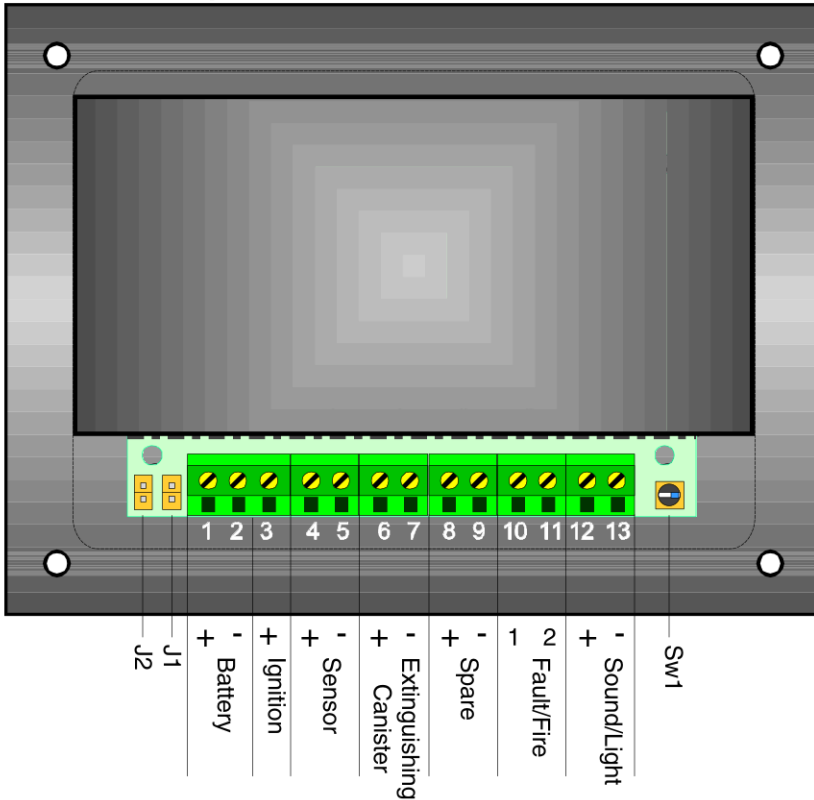

General

The terminals are screw terminals. Wires must have bared and soldered ends before being inserted into the desired terminal slot, the screw is then tightened to secure the wire.

It is recommend that only one wire is connected in each slot.

J is a jumper. A jumper is a plastic cover with metal poles on the inside (see p. 17). It will short the terminals which it is placed on. When the jumper is removed the terminal is no longer shorted.

Sw1 is a switch which may be placed in to positions by turning it with a screwdriver (see p. 17).

Connections

- + Battery:** To the battery +ve terminal (remember fuse)
- Battery:** To the battery negative terminal.
- + Ignition:** To the ignition switch (note the ignition must be supplied from the battery +ve terminal).
- +, - Sensor:** Connection for the sensor cable.
+ and - sensor is shorted during fire.
- +, - Extinguish:** Power to activate the fire extinguisher (monitoring current when control panel is on).
- +,- Spare:** Must be shorted. An open circuit will result in a fault indication.
- 1, 2 Fault/Fire:** Relay which may be used for auxiliary alarm or to control the engine room ventilation.
- +, - Sounder:** Sounder and beacons are connected here.

Settings (programming)

- J1:** If J1 **is** fitted the system can only be activated manually.

If J1 **is not** fitted (**Factory default**) the system may discharge **both** automatically (sensor cable) and manually (buttons on control panel front).
- J2:** If J2 **is** fitted (**Factory default**) the relay Fault/Fire will operate on **both** fault and fire alarm.

If J2 is **not** fitted the relay Fault/Fire will **only** activate on Fire alarms.
- Sw1:** If Sw is active the Fault/Fire terminal is “**Normally Closed**” and the circuit will break during a fire/fault (for use with engine room ventilation, fuel pump, engine shut down etc.)

If Sw1 is inactive (**Factory default**) the Fault/Fire terminal is “**Normally Open**” and the circuit will close on fire / fault.

Auxiliaries

Sounders and optical lights/beacons must be placed so that they can be observed from the typical control points. It may be necessary to purchase and install extra sounders or lights/beacons to ensure that they can be observed from any point on the boat.

Beacon/lights and sounders must be easily observable.

Sensor cable

The sensor cable is supplied complete with an “end of line resistor” and only needs to be connected in one end to work properly.

The cable is placed in the top of the engine room in a way so that a fire will melt the cable. The cable may be secured with cable ties, clips or similar.

The cable must be placed freely so that flames can reach the cable from all sides.

When locating the sensor cable caution should be observed, so as not to place it directly over hot exhaust manifolds, as the sensor cable will activate at 105°C.

Do not shorten the sensor cable

When installing the sensor cable it is important not to damage it. Cable ties should not be tightened so hard that the wires inside the cable may be squeezed together.

The Pyrogen canister

The bracket for the Pyrogen canister must be mounted so that the Pyrogen canister is placed in an effective position. It is important that outlet of the Pyrogen canister is not pointing directly into a wall, escape route, or in a direction where an unintended discharge may expose danger to man or material, see chapter 7 (page 27) for distances that must be observed.

If the Pyrogen canister is of the mono nozzle type (only one protective cover) it should be placed so that it will discharge the Pyrogen over the engine room (the rear side of the canister should be placed toward the engine room wall). If it is the Bi directional type the Pyrogen canister should be placed in the middle of the room.

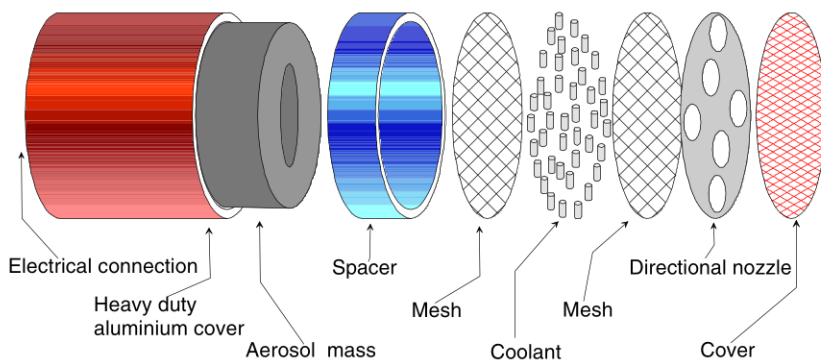

See chapter 7 (page 27) for necessary precessions when installing the canister.

5. Troubleshooting

No light in the control panel

Check that power to the control panel is connected correctly.

Check that the ignition is on and has been on (continuously) for at least 2 minutes.

Check that there is +12 VDC at the control panel.

Check the fuse.

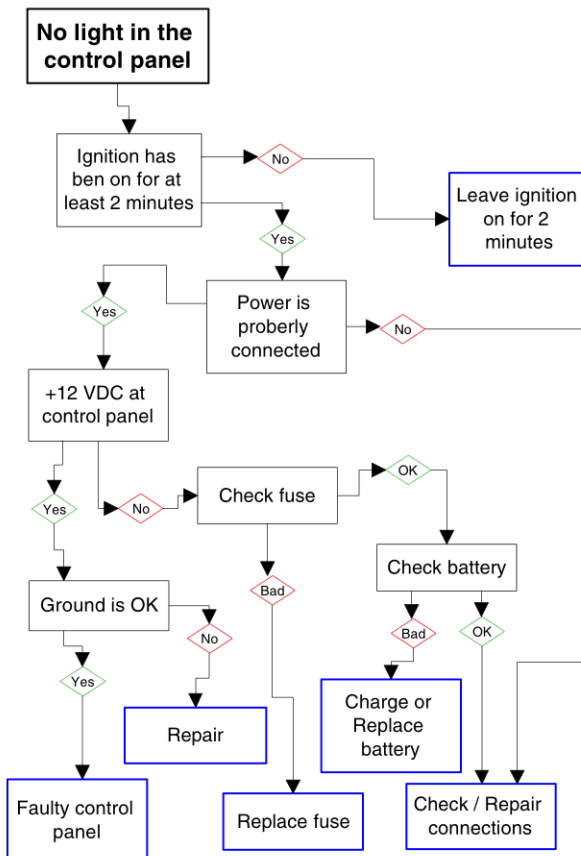

Fault is lit

Check that "Spare" is shorted.

Check that the sensor cable is connected and that the "end of line" resistor (47 K Ω) is correctly installed.

Check all connections (note: A build up of dirt and corrosion may cause the system to malfunction).

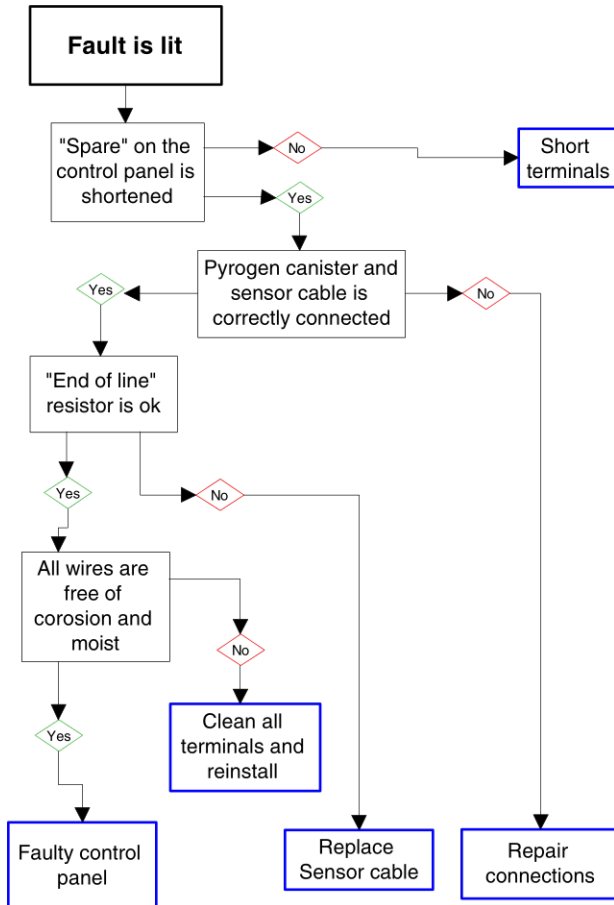

Fire is lit

The sensor cable port is shorted.

Disconnect the sensor cable connection in the connection box (by the engine room) and press the “Reset sounder” for 3 seconds. If the fire indication does not disappear, the cable between the control panel and the connection box is damaged.

When a faulty wire is found it must be replaced. It is not recommended to mend or repair a faulty wire, the whole wire should be replaced.

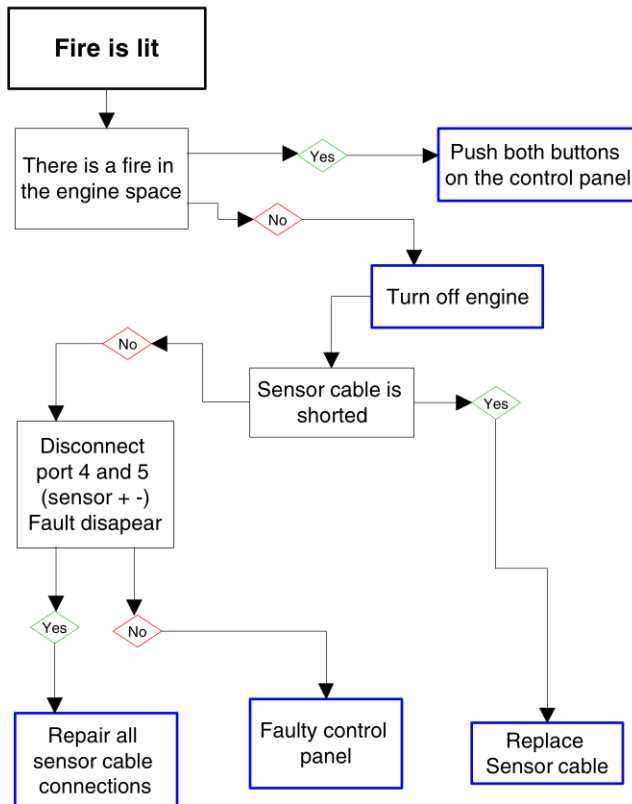

External alarms

General

When ever extra equipment is installed to the system it should be verified that the rating does not exceed the specification of the control panel. If problems occur always check that the equipment is functioning correctly before fault finding on the control panel / system.

Connected to “Sounder” or “Light/Beacon”

Check that the terminals on the sounder or light/beacon are connected properly and that they are clean.

Check that wires are not shorted.

Connected to the Fault/Fire terminals

Check the position of Sw1, if Sw1 is active the relay will open upon alarm (when connected to the ventilation etc.). If Sw 1 is inactive the relay will close upon alarm (alarm horns etc.).

Check the position of J2, if the jumper is fitted the relay will only operate on a fire alarm (eg. ventilation), a fault alarm will not have any effect on the relay when J2 is fitted. If J2 is not fitted a fault will also cause the relay to operate.

6. Accessories and spare parts

Kits

Betegnelsen	Model	Motor rum m³	Vare nr.
Fire mermaid 1m ³ MAG	MAG-2	≤ 1.0	528101
Fire mermaid 2m ³ MAG	MAG-3	≤ 2.0	528102
Fire mermaid 4m ³ MAG	2 × MAG-3	≤ 4.0	528104
Fire mermaid 5m ³ MAG	MAG-5	≤ 5.0	528105
Fire mermaid 7m ³ MAG	MAG-5 + MAG-3	≤ 7.0	528107
Fire mermaid 10m ³ MAG	MAG-4	≤ 10	528110
Fire mermaid 20m ³ MAG	2 × MAG-4	≤ 20	528120
Fire mermaid 30m ³ MAG	3 × MAG-4	≤ 30	528130

Included in the kit

The kit include control panel, sensor cable, connection boxes, sounder, plugs screws etc. as well as the MAG unit(s) for the specified installation.

Accessories

Designation	Dim. [mm]	Item No.
Sensor cable	pr. meter	101150
Sensor cable w. end resistor	4 meter	528012
Sign (Engine room warning)	105 × 149	528030
Sign (For Windscreen)	149 × 74	528031
5w red beacon	ø75×95	407022
Sounder	ø90×35	406030

Spare parts

Designation	Max room volume [m ³]	Dim. [mm]	Weight [kg]	Item No.
Pyrogen Mag -2	1	ø75× 95	0.50	304201
Pyrogen Mag -3	2	ø75×145	0.70	304202
Pyrogen Mag -5	5	ø95×190	1.83	304205
Pyrogen Mag -4	10	ø95×350	4.50	304210
Installation manual		A5		528360
Installation diagram		A3		528367
Cable socket		6.3 mm		516100
Distribution box		70×70×37		706450
SS inst. screws		UHT 4 × 20		401443
Sounder				501853
Fire proof cable		2×0.75 IEC 331		101142

Pictures of different Pyrogen MAG canisters (Vehicle kit is shown)



Picture of MAG -3 Pyrogen canister



Control panel after installation



Sounder at top corner and ignition switch in lower right corner.

7. Pyrogen safety data

Limitations

The Pyrogen extinguishant, being a hot aerosol, has a tendency to rise upward on its release due to buoyancy forces. As such, the aspect of spatial distribution needs to be addressed.

Height limitation:

MAG-2	1.25 m
MAG-3	2.50 m
MAG-5	3.50 m
MAG-4	3.50 m

Due to the potential hazard of high temperatures below minimum distances, these should always be observed during installation.

Safe distance

MAG-2	300 mm
MAG-3	400 mm
MAG-5	700 mm
MAG-4	1000 mm



FIRE MERMAID X1

Visibility

Pyrogen is intended to be used in Normally unoccupied areas principally due to the high obscuration caused by the aerosol during and after discharge

Oxygen levels

Pyrogen chemically attacks the fire, breaking the flame chain reaction. It does not extinguish fires by oxygen depletion. After discharge, oxygen levels will remain at or about normal.

Toxicity

Inadvertent exposure to Pyrogen aerosol should always be avoided. Toxicological information refers to an inadvertent exposure to the aerosol in the event of accidental discharge in a non-fire situation.

The main ingredients of Pyrogen aerosol are solid potassium carbonates, nitrogen gas, carbon dioxide gas and water vapour. At normal extinguishing concentrations these products present little health hazard to personnel. However, small amounts of potentially hazardous by-products of the aerosol-generating combustion reaction, such as carbon monoxide and nitrogen oxides will be produced. Their toxicological characteristics depend upon the actual concentrations achieved and duration of exposure.

Exposure to Pyrogen in a standard system, for up to 5 minutes, is considered to represent a minor risk to personnel and may cause moderate local irritation of the upper respiratory tract and to the eyes.



Post fire exposure

One of the key advantages of Pyrogen over Halon and some of the replacement agents available, is that Pyrogen does not produce toxic nor highly corrosive halogen acids when exposed to fire or hot surfaces. Safety requirements dictate, however that unnecessary exposure to post-fire atmospheres should be avoided. Caution Venting of the post-fire atmosphere should be to an open-air area, when possible, to prevent the inadvertent exposure of personnel to any combustion products of the fire and aerosol-generating reaction.

Thermal hazard

There is a potential hazard of high temperatures (250°C +) of Pyrogen aerosol at the end-plate nozzle. Outside the safe distance the temperature does not exceed 75°C. Those distances should be observed during installation.

Immediately after discharge the generators can be hot, therefore, protective gloves should be worn before handling generators up to 15 minutes after discharge.

Hot work

As naked flame or prolonged exposure to temperatures above 400°C may cause activation of the generators, hot work must not be carried out within the vicinity of any generators. If so they shall be removed prior to any hot work being carried out.

Re-entry

Following the use of Pyrogen, personnel should not enter the protected area until it has been thoroughly ventilated. Exposure to the fire by-products and extinguishant mixture should be avoided. Wearing a respirator or other available means of protection may be required should it be necessary to enter the area before it is fully ventilated.

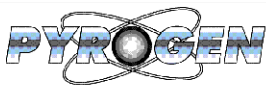

FIRE MERMAID X1

Clean-up

Following a system discharge the aerosol particles that have settled should be vacuumed, blown, brushed or, if appropriate, washed away. Protective gloves and goggles should be worn. A respirator or mask may be required

Large amounts of residue that is allowed to absorb moisture become electrically conductive over a period of time

Dangerous good classification

Pyrogen is a Class 4.1 article in accordance with the United Nations Dangerous Goods Classification Code.

CoSHH statement

A by-product of Pyrogen aerosol-generating combustion reaction are fine potassium carbonate particles, small enough to be respiration by persons not wearing RPE. There are no known toxicological long term effects of these soluble micron sized particles, and physiological effects of deep lung penetration are usually a concern for insoluble sub-micron particles as they can interfere with pulmonary functions

However, there are clear European guidelines controlling the exposure of persons to fine particles, irrespective of their nature. Further information is available in BS EN 481:1993 & BS EN 451:1992 and in CoSHH supportive documents EH40/98 & EH44 and MDHS 14/2.

Noise

The sound output and frequency at the time of activation and during discharge is similar to the produced by other extinguishing agents. Consequently, no specific precautions need to be taken.



8. Technical specification

Power supply

Voltage.....	8 - 15 VDC
Stand by current.....	0.28 mA
Normal current.....	50 mA
Alarm current (max.).....	230 mA
Discharge current (max.).....	1 A

Ignition

From boat ignition.....	8 - 15 VDC
-------------------------	------------

Sensor cable

Voltage.....	5 VDC
Normal current (max.).....	0.5 mA
Alarm current (max.).....	1.0 mA
Sensor cable end resistor.....	43 k Ω

Discharge signal

Voltage.....	8 - 15 VDC	(as battery)
Current.....	1 A	

Discharge monitoring

Voltage.....	5 VDC
Current.....	0.3 mA

Sounder connection

Voltage.....	8 - 15 VDC	(as battery)
Current (max.).....	200 mA	

Spare

Voltage.....	5 VDC
Current (max.).....	1 mA

Fault/Fire (non potential relay)

Voltage (max.).....	60 VDC
Current (max.).....	0.5 A

Dimensions

Front HxBxD.....	90x120x5 mm
Cut-out.....	70x100 mm
Depth in cut-out.....	40 mm
Weight.....	250 g.

Sensor cable end of line resistor

Resistance.....	43 K Ω
Rating.....	¼ W

Limited life components

Pyrogen.....	10 years
--------------	----------



9. Fire procedure

**In the event of a fire
Follow these directions**

1. Check that engine room has been evacuated
2. Check that the engine room is closed
3. Press both buttons on the control panel simultaneously for 5 sec
4. Turn off the engine
5. Shut down all power to the engine room (Electricity/gas/fuel)
6. Make a role call
7. Verify that nobody is missing or unaccounted for
8. Verify that the fire is extinguished (only open the hatches slightly. Caution must be used not to become exposed to the fire or its bi-products)
9. Find and repair the cause of the fire
10. Re-establish the fire extinguishing system



10. Commissioning check list

- 1. The control panel is in an accessible place.....
- 2. Power is properly connected
- 3. Sensor cable is properly installed
- 4. Discharge cable is properly installed
- 5. Warning signs are installed

Disconnect the discharge cable

Connect the power to the control panel and turn the ignition on

- 1. The control panel lights up after app.1½ min.
- 2. Fault is lit on in the control panel.....

Sensor cable is shorted

- 1. After app. 5 sec. the fire alarm starts.....

The alarm is reset (push "Reset sounder")

The sensor cable is disconnected

- 1. After 1 sec. fault appears

The control panel is activated manually

- 1. After app. 1-2 sec. Alarm starts.....

The Fire extinguisher is reconnected after the test

Distributor: _____ tel.: _____

Installation company: _____ tel.: _____

Installation date: _

The system is correctly installed and found free of faults:

_____ place _____ date _____ Signature



11. Service log

Any changes, modifications, and repairs to the system or its components are to be noted on these pages. Any records must contain date name and signature.

Date of purchase: _____

Name and address of supplier: _____

Date of installation: _____

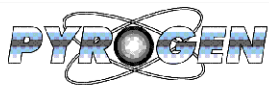

FIRE MERMAID X1

12. Installation templates

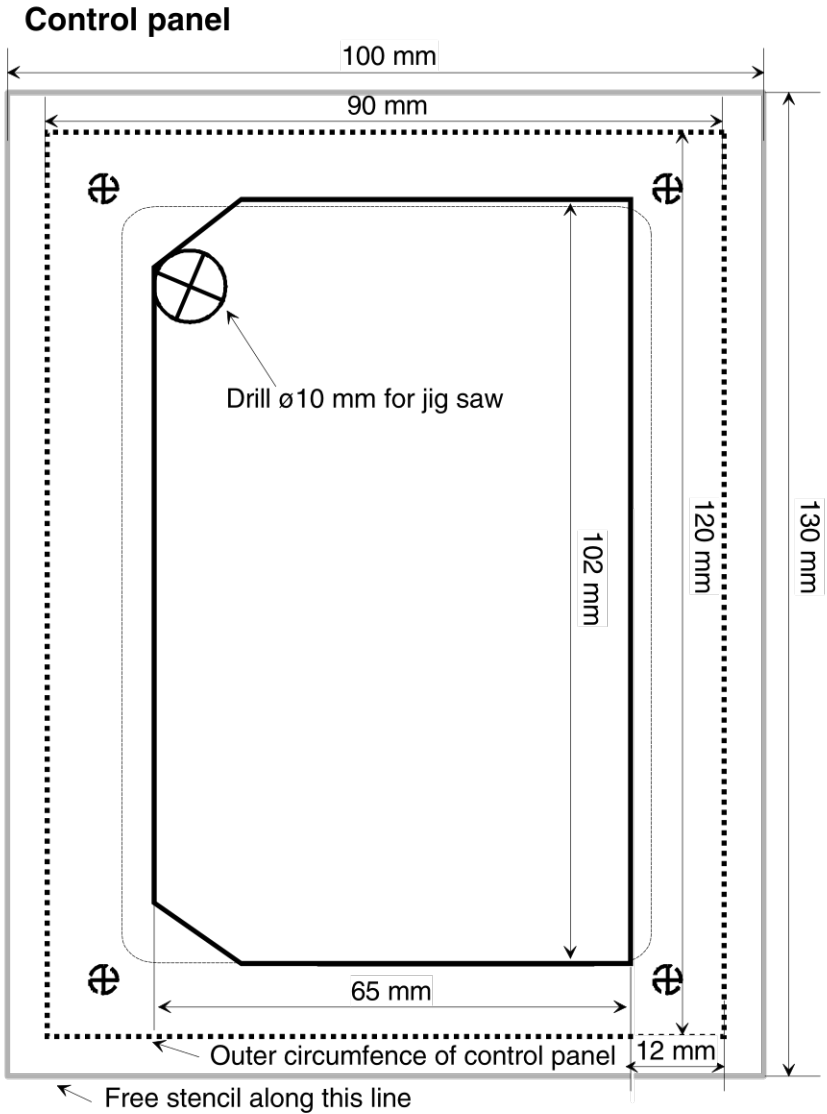

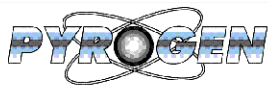

FIRE MERMAID X1

Pyrogen canister mount

View of bracket foot.

