

PyroSense SP-1

Fire Detection & Fire Supression system

Installation & User Manual

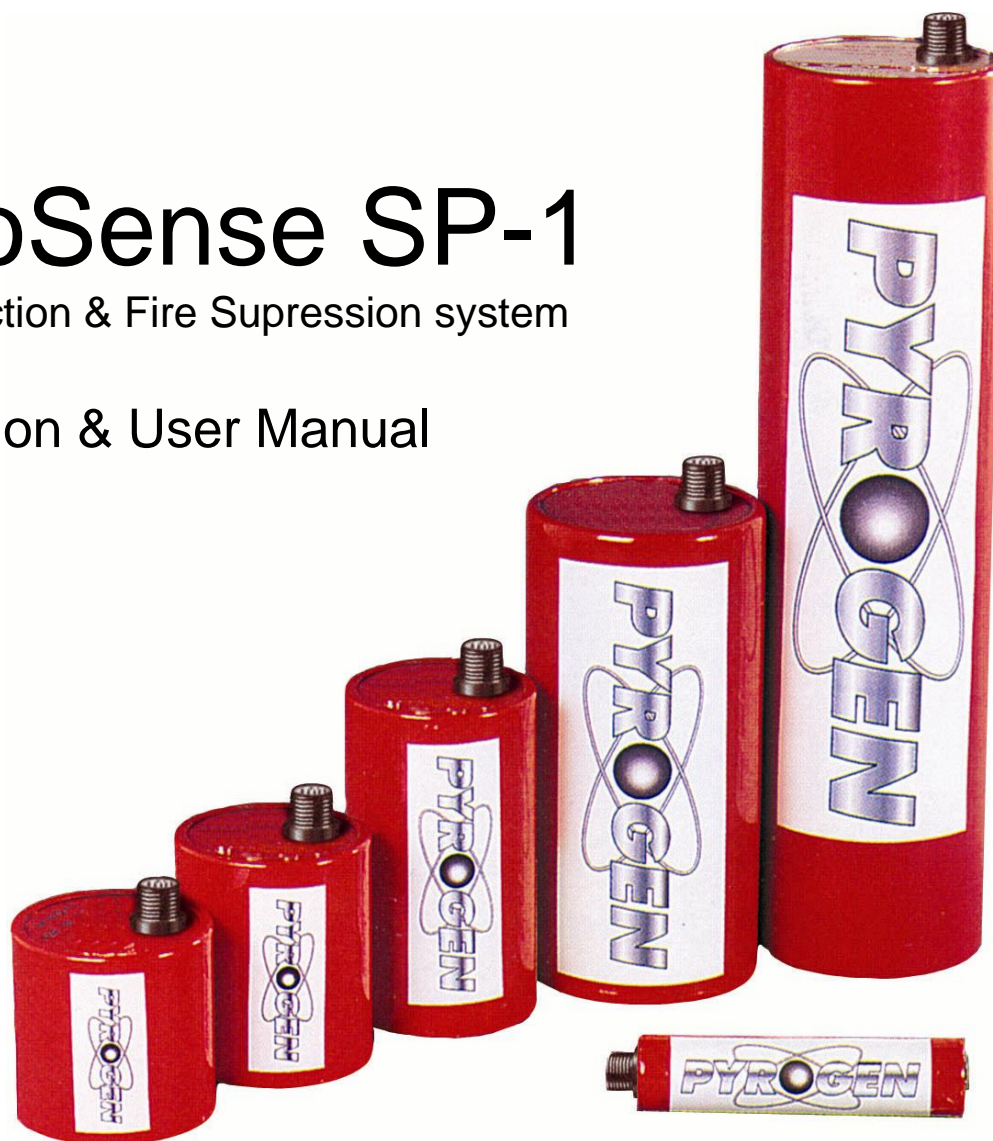

Control device

Active Fire Protection

PyroSense SP-1

Pyrogen Ltd.
Gilnow Mill Business Centre
Spa Road
Bolton U.K.
BL1 4LF

Tele: +44 (0) 1204 373300
Fax: +44 (0) 1204 373355

e.mail: pyrogen@btconnect.com
www.pyrogen.com

CONTENT

User instructions	4
In the event of a Fire being discovered in the Engine Room	4
In the event of an Alarm	4
In the event of a Fault	4
Alarms	4
General	5
PyroSense SP-1	5
Fire extinguishing	5
Fault Indications	5
Functional description PyroSense SP-1	6
When the system is discharged	6
The System Components	6
The MAG generator	6
What is Pyrogen?	6
How does Pyrogen work ?	7
The SP1 control panel	7
Monitoring.....	7
Initial start up	7
Service	8
General.....	8
Service Life.....	9
After discharge.....	9
Procedure for replacing the MAG generator	9
Fire extinguishing with Pyrogen and safety	10
High temperatures.....	10
Hot work	10
Cleaning after discharge	10
Reduced visibility.....	10
Oxygen level.....	10
Toxicity	11
Health considerations.....	11
Dangerous good declaration	11
Installation	11
General.....	11
Necessary preparations	11
Equipment and material	11
Tools.....	12
Order of connection.....	12
Installation of the MAG generator	13
Minimum clearances	13
Limitations	13
Height Limitations.....	14
Typical installations	14
Mono Generator Fixings.....	14
Bi-Directional Generator Fixings	15
TECHNICAL SPECIFICATION PYROGEN.....	16
Canister Characteristics	16
Electrical (Thermal) Characteristics	16
Aerosol Characteristics (At Maximum Design Concentration)	16
Classifications	16
Technical parameters of MAG generators	17
The control panel PyroSense SP-1	17
Terminal strip connections	18
Conductors and cables	18
Optional accessories	18
The sensor cable.....	18
Setting the programming DIP-switch	19

“Cause effect” matrix.....	19
Programming table Comments.....	20
Software priorities.....	21
Power LED.....	21
Activated LED.....	21
Test functions.....	21
Stage 3 – Testing the outputs and remaining inputs.....	21
Trouble shooting.....	22
General.....	22
No light in the Power lamp.....	23
Fault LED is lit.....	24
Check MAG Generator.....	24
The Fault LED is lit.....	25
Check loop 1 – Sensor cable.....	25
Troubleshooting procedure – sensor cable.....	25
Fault LED is lit.....	26
Check loop 2 – Alarm detector(s).....	26
Troubleshooting procedure – Loop 2.....	26
Fault LED is lit.....	27
Check external manual discharge loop.....	27
Troubleshooting procedure – manual discharge.....	27
Alarm LED is lit.....	28
Alarm + Activated LED is lit.....	29
List of delivered items.....	30
Optional equipment.....	30
Accessories and spare parts.....	31
Thermal activation.....	33
Technical data PyroSense SP-1.....	34
Installation check list.....	35
Installation LOG.....	36
Setting of DIP-switch.....	36
SERVICE LOG.....	37
Certificate of conformity.....	38
Installation diagram Basic Kit.....	39
Installation diagram optional Manual Discharge.....	40
Installation diagram optional Spot detector (smoke/heat).....	41
NOTES.....	45

User instructions

In the event of a Fire being discovered in the Engine Room

1. Check that the engine room has been evacuated.
2. Stop the engine and shut of the fuel supply.
3. Shut Down Engine room ventilation, if any, close all hatches, doors or other openings.
4. Activate the extinguishing system by simultaneously pressing both push buttons on the control panel.
5. Disconnect all power sources (elec,gas ect)
6. Check that all personel are accounted for.
7. Be prepared for manual intervention by help of portable extinguisher.
8. Think safety- lifejackets, survival suits, emergency signals, alert the coast guard etc.
9. After 5 minutes check that the fire is extinguished. Only open doors or hatches slightly and ensure you are protected from any fire bi-products or gases.

In the event of an Alarm

When an alarm appears on the control panel:

1. Check if it is Fire or a Fault alarm indication.
2. If it's a Fire alarm (i.e. Alarm LED activated) see above In event of a Fire
3. If it's a Fault alarm (i.e. Fault LED activated) see below In event of a Fault

In the event of a Fault

When a fault occurs:

1. Check which lamps are illuminated and deactivate acoustic alarm by pressing left button "Silence".
2. Follow the procedure on page 22.
3. When the reason for Fault alarm has been detected and the corrective action has been taken, the control panel can be reset by pressing right button "Reset". It is not possible to reset the control panel until the corrective action has been carried out.

Alarms

Fire alarm = Alarm indicator illuminated and buzzer sounds continuously.

Discharged = Activated indicator is illuminated and buzzer makes pulsating sound.

Fault = Fault indicator is illuminated and buzzer sounds continously.

General

PyroSense SP-1

PyroSense SP-1 is a combined alarm, monitoring and discharge panel used for controlling Pyrogen MAG generators. It can be connected to, & monitor information from, spot detectors, which could be smoke (optical/ionisation), heat, water or gas as well as a thermal sensing cable.

The control panel can be programmed to operate in either automatic mode, which after receiving a signal from one of the detectors or sensors indicating the existence of a fire, will fire the MAG units remotely after a preset delay, or manual mode, allowing for review of the situation before the MAG units are activated from the panel. See chapter "Applications".

PyroSense SP-1 is programmed at the manufacturing point to just indicate Fire (i.e. Manual Mode), However the panel can be re-configured to an Automatic setting very easily by altering the DIP situated on the rear of control panel (Please review the table on page 19).

On the back of the panel there are a number of terminals to allow the user to connect external sounders, Warning beacons, relay connections for automatic engine shutdown in event of fire as well as an external manual discharge button should this be required.

In the event of fire the panel will illuminate the Alarm LED and the warning sounders/beacons will activate, if the panel is set in Manual Mode the Pyrogen MAG generators can only be activated by, simultaneously, pressing, and holding down both the RED buttons on the front of the panel for 5 seconds, this will activate the Discharge LED and the units will activate. If the panel has been configured to operate in a fully automatic mode the panel will, once it has received an indication of fire from the detectors/sensors, automatically activate the Pyrogen MAG generators after a 20 second warning time.

In order to reset (stop) any activated sounders press the "Silence" button. The Alarm LED will remain illuminated and can only be reset by pressing the "Reset" button.

In the event that the a fire has been detected by a Thermal Sensing Cable the Fault LED will remain illuminated until such time as the cable is replaced.

Fire extinguishing

If the MAG unit is discharged, the LED "activated" will be illuminated, the buzzer (and external siren / alarm if any) will be pulsating.

Sound is reset by pressing the "Silence Button".

If programmed in automatic mode, where the activation is done by signals from detectors, the "Alarm" LED will be illuminated as well.

If alarm is triggered by the sensor cable, the LED in the control panel will remain illuminated until the sensor cable is renewed or disconnected. If the sensor cable is disconnected only "Fault" will be indicated on the control panel. The "Fault" signal will be given until the sensor cable is replaced.

Fault Indications

The Fault LED will illuminate if:

- The cable for the Pyrogen MAG generator goes open
- The cable-loop for the external manual discharge button goes open or short circuit
- The alarm-loop 1 goes open
- The alarm-loop 2 goes open or short circuit
- There is a problem with any of the LEDs in the control panel. All LEDs are double and the spare LED will take over if the main LED is broken.

Fault will be indicated by a continuous tone from the sounder, the "Fault " LED will be illuminated and alarm loop 1 will give a steady signal for any external siren or alarms that might be connected to the system.

Functional description PyroSense SP-1

The PyroSense SP-1 has two alarm loops. Alarm loop 1 is the primarily, used to connect the thermal sensing cable, while alarm loop 2 can be used to connect other spot, smoke (optical/ionisation) or heat detectors.

At temperatures >180°C the thermal sensing cable, connected to alarm loop 1, will short circuit and the panel will activate the alarm. If the control panel is programmed for automatic mode the alarm will sound for 20 seconds prior to discharge of the Pyrogen MAG generator/s. In this mode output 2 will be activated simultaneously with the alarm and without any delay. This signal might be used for closing the ventilation, and stopping the engine. Output 1 might be used for any external sirens or alarms. This output follows the internal buzzer.

The same will happen if alarm signal is given from detectors connected to loop 2.

As mentioned it is also possible to use one of the loops to activate automatic discharge of the MAG unit and use the other loop for activating alarm only (Firealarm). Selection of which loop to use for the alternative purposes is done by help of the functional switches at the rear of the control panel. For extra safety detectors might be connected to both loops, and the control panel programmed to discharge the MAG generator only if alarm signal is given from both detectors.

Discharge of MAG generators also can be activated by simultaneously pressing the two pushbuttons, on the frontside of the control panel, marked "Press" for minimum 5 seconds. A pulsating sound will confirm that manual discharge signal is activated. After 5 seconds the sound will stop pulsating and a uniformed sound will be heard. At this moment the MAG generator will be discharged into the protected enclosure and extinguish the Fire within seconds. Discharge of the MAG unit might also be activated by external manual push button.

PyroSense SP-1 is prepared for the use of a manual external discharge push button. This input is also monitored and short circuit or broken loop will give normal fault alarm.

In event of a fire the visual and acoustic alarms will be conscious, and turn to pulsating when the Pyrogen MAG generator is discharged .

Internal buzzer and output 1 can be reset by pressing the "Silence" button. The alarm signal will be active until the reset button is pressed. If the detector is still activated the buzzer and the output will again be activated.

When the system is discharged

In the event that the system is used and the MAG units are discharged, they will need to be replaced in order to obtain a functional extinguishing system. (See "service" and "after discharge" page 9)

The System Components

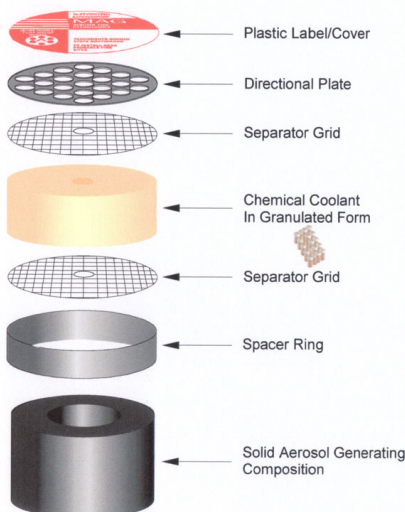

The MAG generator

The PyroSense-SP1 control panel is designed to monitor and discharge the Pyrogen aerosol suppression system. The suppression system is based on the use of MAG generators directly activated by an electrical impulse from the control panel.

What is Pyrogen?

Pyrogen is a self-generated Aerosol Fire Extinguishing Agent, and is *one of the most efficient Halon Alternative products currently available.*

As the aerosol produced is self-generated it requires *no pressure cylinders.* Pyrogen's method of aerosol generation provides a sufficient driving force for a rapid discharge and efficient distribution of the extinguishing agent. *No piping is required.*

MAG generators manufactured from marine grade are very compact and they are normally placed inside the protected enclosure.

The Pyrogen units are called MAG generator (Mass Aerosol Generator).

Operation of the generator is either electrical automatic, electrical manual, thermal automatic or, on the grenade units, by pin removal.

Pyrogen aerosol is a whitish gas-like medium that is close in density to air. *Small particle size ensures three-dimensional distribution qualities and long suspension times.*

Pyrogen aerosol is non-conductive and non-corrosive.

As Pyrogen aerosol stays in suspension for extended periods, it can be removed from the protected area by any airflow. Any solid fraction of the aerosol that has settled can easily be brushed, blown or washed away.

How does Pyrogen work ?

The principle of extinguishing action employed by Pyrogen is unique, a special solid chemical, when electrically or thermally activated, produces combustion products, micron sized dry chemical particles & gases. Dry chemical particles (mainly potassium carbonates) & a gaseous mixture (mainly carbon dioxide, nitrogen & water vapour) mix together into a uniform fire-extinguishing aerosol.

Before being released into a protected area the hot aerosol propels itself through a unique solid chemical coolant, which decomposes absorbing huge amounts of heat, thus ensuring a flameless discharge and uniform distribution of the cool aerosol within the area.

The high rate of aerosol discharge ensures a tremendous knockdown effect. The micron sized particles exhibit gas-like three-dimensional qualities that allow the agent to rapidly distribute throughout the protected area and reach even the most concealed and shielded locations.

Homogenous distribution is achieved in a matter of seconds, while long holding times help to prevent any re-ignition of the fire.

The SP1 control panel

WARNING! Prior to connecting MAG generators ensure the wires leading to the generators are not carrying voltage. Connection of MAG generators should always be the last function in electrical wiring procedure.

The Pyrosense-SP1 is an extremely compact control panel allowing adaptability to most standard instrument modules (VDO instruments). The panel is both robust and water resistant. All cables, whether they are for the detectors, power supply or for the MAG generators are connected at the rear of the panel.



Monitoring

All inputs will be monitored continuously assuming that the panel remains connected to the power supply. Any short or open circuit signals will result in a "Fault" alarm.

Initial start up

When electrical source is first connected to panel it will automatically commence a start up/system test procedure. This will involve all the LED's illuminating in sequence and the internal sounder will give a sequential tone. When this sequence has finished, the system is operational and provided no alarm signal from any of the loops, and that the power source remains healthy, the "Power" lamp will illuminate.

WARNING! Prior to connecting MAG generators ensure the wires leading to the generators are not carrying voltage. Connection of MAG generators should always be the last function in electrical wiring procedure.

It is important that prior to the installation of MAG generators the integrity and resistance of the electric ignition circuit for each MAG generator be checked with the use of a **digital** multi-meter. The maximum test current shall not exceed 50 milliamps for a period of 5 minutes. The monitoring current shall not exceed 5 milliamps.

Resistance of the electric activation circuit shall be within 2.5-4.5 Ohms.

It is also important to check earth fault of every MAG generator. Earth fault resistance must not be less than 10 mOhm.

Note! In order to save power the "Power" LED does not illuminate until the ignition is switched on.

Should the user wish to run the start up/system test procedure at any time, this can be achieved by pressing the "Silence" button while electrical power is connected (see page 21). This will ensure all inputs & outputs are healthy.

Note! Prior to such a test it is important to replace the MAG generator with a test lamp or the end cap originally supplied.

Service

General

WARNING! Prior to the start of ANY maintenance work, always ensure as the first step, that wiring to all Pyrogen generator loops have been electrically isolated. Should thermal automatic operation be used, unscrew the fire conducting cord holders from all the Pyrogen generators and replace them with the end caps originally supplied. Failure to do so may result in unwanted spurious discharge.

The PyroSence SP1 does not require any direct maintenance as the panel is self monitoring, however it is important that a visual inspection of all the elements of the system, including Dectectors, Sensors, Sounders, Beacons, Remote Manual Release Switches & Pyrogen MAG Generators, is performed on a monthly basis to ensure that no part of the system has been damaged. Any items found to be cracked, dented or loose should be recified or replaced.

The visual inspection should consist of:

- Checking that all cabling is securely fastened and that the insulation is not damaged.
- Checking that all electrical connections and junction boxes are properly sealed. Moisture and/or corrosion in connections or junction boxes may, at worst case, discharge the system.
- Checking that the MAG unit is not dented or damaged (In the event that a MAG generator has been damaged or dented it should be disconnected and replaced immediately) and that it has remained properly secured in its fixings.
- Checking the replacement date for the MAG unit.
- Ensure that no obstacles have been placed in front of the MAG units discharge nozzle (end plates) See installation instructions page 11-13.

Service Life

The service life of the Pyrogen MAG unit in total flooding applications under normal conditions is stated as 10 years from installation, however where the generator is used in local applications or under conditions of aggressive environment this may be reduced to five years. For further clarification of the service life please contact your local Pyrogen distributor.

For the disposal of un-discharged generators please contact one of the following:

TECHNOR ASA

Dusavikveien 39

P.O.Box 658

4003

STAVANGER

Tel: +47 51 84 41 00

Fax: +47 51 84 41 01

E-mail: mail@technor.no

Web: www.technor.no

Pyrogen (UK)

Gilnow Mill Business Centre

Spa Road, Bolton.

BL1 4LF

UK

Tel: +44 (0) 1204 373300

Fax: +44 (0) 1204 373355

E-mail: pyrogen@btconnect.com

Web: www.pyrogen.co.uk

Distributor:

After discharge

Once a Pyrogen Generator has been activated it is no longer of any use and must be replaced with a complete unit. If the sensor cable has activated the system then this will need to be replaced also.

Disposal of deactivated Pyrogen generators can be made along with general waste as the remaining canisters contain on harmful materials. However if the spent canisters are returned to Pyrogen Ltd. or one of Pyrogens distributors, along with a detailed report on the incident that lead to the activation, new generators may be purchased at a reduced cost.

Procedure for replacing the MAG generator

Warning: When replacing MAG generators, be aware that immediately after discharge the canisters outer surface may exceed 200°C. Therefore, protective gloves should be worn before handling generators until at least 15 minutes after discharge.

- Disconnect the power supply for the control panel
- Disconnect the connector on the spent (discharged) MAG generator
- Remove the spent (discharged) MAG generator from the bracket (Please note the warning at the top of this section)
- If the discharge was due to a signal from the Thermal sensing cable install a new cable.
- After ensuring that the brackets and fixings are okay fit the new MAG generator. Ensure that should there be any damage to the connector or flying lead this is replaced.
- Reconnect the power supply to the control panel
- Switch on the ignition

WARNING! Prior to connecting MAG generators ensure the wires leading to the generators are not carrying voltage. Connection of MAG generators should always be the last function in electrical wiring procedure.

It is important that prior to the installation of MAG generators the integrity and resistance of the electric ignition circuit for each MAG generator be checked with the use of a **digital** multi-meter. The maximum test current shall not exceed 50 milliamps for a period of 5 minutes. The monitoring current shall not exceed 5 milliamps.

Resistance of the electric activation circuit shall be within 2.5-4.5 Ohms.

It is also important to check earth fault of every MAG generator. Earth fault resistance must not be less than 10 mOhm.

- Reconnect the MAG Generator once the connector has been tested to ensure it is carrying no voltage (beyond the expected monitoring current)
- Ensure that the control panel does not indicate any "Fault".

Fire extinguishing with Pyrogen and safety

One of the main advantages of Pyrogen, compared to conventional chemical extinguishing agents, is the fact that Pyrogen does not decompose into damaging by-products when in contact with hot surfaces. This in fact means no secondary damage can be caused after the discharge of the extinguishing agent.

For safety reasons care should be taken not to expose people to the atmosphere in the enclosure immediately after discharge of Pyrogen. The enclosure should preferably be ventilated, directly into the open air. Inhalation of the decomposition products from the fire itself or inhalation of the Pyrogen aerosol should be avoided. If for any reason it is a necessary to enter the protected area prior to ventilation having taken place, suitable RPE & other available means of protection should be used.

High temperatures

During discharge the Pyrogen MAG unit can reach temperatures of approximately 250°C at the end cover (the nozzle) therefore it is important that the minimum safe distances be observed when the installation of the MAG generators is being considered. Please see the table on pages 13-14. Temperatures beyond the minimum safe distances will not exceed 75°C

Hot work

As naked flame or prolonged exposure to temperatures above 300°C may cause activation of the generators, hot work must not be carried out within the vicinity of any generator or thermal sensing cables. If hot works are absolutely necessary the Pyrogen generators & thermal cables should be removed to a safe area prior to any work being carried out.

Cleaning after discharge

Following a system discharge the aerosol particles that have settled should be vacuumed, blown, brushed or, if appropriate, washed away. Protective gloves and goggles should be worn. A respirator or mask should be worn. Large amounts of residue that are allowed to absorb moisture may become electrically conductive over a period of time.

Reduced visibility

Pyrogen is intended for use in normally unoccupied areas principally due to the high obscuration caused by the aerosol during and after discharge.

Oxygen level

Pyrogen chemically attacks the fire, breaking the flame chain reaction. It does not extinguish fires by oxygen depletion. After discharge, oxygen levels will remain at or about normal.

Toxicity

Inadvertent exposure to Pyrogen aerosol should always be avoided. Toxicological information refers to an inadvertent exposure to the aerosol in the event of accidental discharge in a non-fire situation.

The main ingredients of the Pyrogen aerosol are solid potassium carbonates, nitrogen gas, carbon dioxide gas and water vapour. At normal extinguishing concentrations these products present little health hazard to personnel. However, small amounts of potentially hazardous by-products of the aerosol-generating combustion reaction, such as carbon monoxide and nitrogen oxides will be produced. Their actual concentrations depend on Pyrogen design factor used and type of enclosure under protection. Their toxicological characteristics depend upon the actual concentrations achieved and duration of exposure.

Exposure to a Pyrogen design factor of 100 g/m^3 , which is typical for class B fires in total flooding applications, for up to 5 minutes, is normally considered to represent a minor risk to personnel and may cause only moderate local irritation of the upper respiratory tract and to the eyes.

Health considerations

A by-product of Pyrogen aerosol-generating combustion reaction is fine potassium carbonate particles, small enough to be inhaled by persons not wearing RPE. There are no known toxicological long-term effects of these soluble micron sized particles, and physiological effects of deep lung penetration are usually a concern for insoluble sub-micron particles as they can interfere with pulmonary functions.

However, there are clear European guidelines controlling the exposure of persons to fine particles, irrespective of their nature. Further information is available in BS EN 481:1993 & BS EN 451:1993, and in CoSHH supportive documents EH40/98 & EH44 and MDHS 14/2.

Noise. The sound output & frequency at the time of activation and during discharge is similar to that produced by other extinguishing agents. Consequently, no specific precautions need to be taken.

Dangerous good declaration

Pyrogen is a Class 4.1 article in accordance with the United Nations Dangerous Goods Classification Code.

Installation

General

Prior to installation of the any Pyrogen system the engine must be shut down and the + ve terminal of the battery disconnected. The battery shall not be reconnected until the installation is finalised. Please ensure that you have read the installation manual carefully, planned and prepared the installation in detail, and have ensured that you have all equipment and tools required available prior to start up of the installation.

Necessary preparations

The following equipment / materials should be prepared prior to installation:

Equipment and material

1. Fireproof screened cable type Radox FR 125 2x 0.75 (15m)
2. Available outlet on the fuse box (min. 2A)
3. Junction box (ELE 1242802)
4. Fastening equipment (cable clips, screws, Schotts tape, cable strips etc.)
5. Sensor cable for heat detection (if to be used)
6. Adhesive sign "Warning" (SPE-PYR-1)
7. Adhesive sign "Service" (SPE-PYR-2)

Tools

1. Hand tools screwdriver and pincers
2. Drill with 3.0 & 10mm drill bit
3. Hole cutter for making circular hole with 60mm Ø (if SP-1 is to be flush mounted)

Order of connection

1. Turn off the engine and disconnect the batteries +ve pole.
2. Make a 60mm hole for the control panel. Alternatively the control panel may be installed in a spare instrument module, or separate box. It is important that the control panel (SP-1) is installed in an easily accessible space, in the event of a fire and in such a way that a fire in the engine room would not block the access to the control panel.
3. Fix the MAG unit/s, detectors (if any), remote manual discharge switch and the thermal sensing cable, should these be required.
4. Install the junction box in the vicinity of the engine room or in the engine room itself.
5. Install cable from the control panel (SP-1) and the junction box (for connection of MAG generator/s)
6. Install the cable from the control panel SP-1 to the junction box for the sensor cable (If required)
7. Install cable from the control panel SP-1 to the junction box for spot detectors (If required)
8. Install cable from the control panel SP-1 to the remote manual discharge switch (If required) (Radox 125 FR 2 x 0.75mm²)
9. Install the wire from SP-1 to the ignition switch (Red 1 x 0.75mm²)
10. Install the wires from the fuse box to the control panel SP-1 (2 x 1.5 mm²)
11. Install the cables for auxiliary equipment such as sounders, beacons, ventilation and /or automatic engine stop etc.
12. If used connect the thermal sensing cable to the junction box.
13. If used connect any extra sounders or beacons.
14. Connect any other auxiliary equipment (ventilation, automatic engine stop etc.)
15. If required connect the remote manual discharge switch.
16. Connect wire from main ignition switch to Pyrosense SP-1 control panel.
17. Connect wires for power in the fuse box and Pyrosense SP-1 control panel.
18. Configure the DIP-switches for the installation (rear of panel)
19. Confirm & verify all the connections.
20. Reconnect the battery.
21. Switch on the ignition & check that the "Power" LED on the control panel is illuminated.
22. Check to ensure that neither the "Alarm" nor "Activated" LED's are activated on the SP-1 control panel. The "Fault" LED will be illuminated as the Pyrogen MAG generators have not yet been connected. However before proceeding further with the installation procedure, check to ensure that at this stage that the cables leading to and intended for the MAG generators are carrying no voltage (beyond the expected monitoring current).
23. If OK switch the ignition off and disconnect the batteries +ve terminal.

Note: It is important that prior to the installation of MAG generators the integrity and resistance of the electric ignition circuit for each MAG generator be checked with the use of a **digital** multi-meter. The maximum test current shall not exceed 50 milliamps for a period of 5 minutes. The monitoring current shall not exceed 5 milliamps.

Resistance of the electric activation circuit shall be within 2.5-4.5 Ohms.

It is also important to check earth fault of every MAG generator. Earth fault resistance must not be less than 10 mOhm.

WARNING! Prior to connecting MAG generators ensure the wires leading to the generators are not carrying voltage. Connection of MAG generators should always be the last function in electrical wiring procedure.

24. Connect the MAG generator/s
25. Re-connect the batteries +ve terminal
26. Switch on the ignition
27. After the control panel has run through the initially start-up sequence the "Power" LED should be the only LED illuminated.
28. Fix "Warning" signs & operating instructions as well as any location specific Fire procedure instructions at the control panel and any remote activation points.
29. Affix Installation date, future service date & maintenance or replacement date information on the MAG generator.
30. Finally ensure that the Installation details, maintenance protocol and checklist on pages 35-36 have been completed

If at this point, or indeed at any point during the installation, there are any problems with the system, please refer to the chapter on "Trouble Shooting".

Installation of the MAG generator

The Pyrogen MAG generator/s should be installed in the best possible position to ensure that the aerosol will have chance to mix evenly within the, to be, protected area. Areas where the MAG generator will be exposed to high temperatures (+50°C) or high humidity should be avoided. Also due to the high temperature of the aerosol on discharge it is advised to ensure that they are not directed towards sensitive or delicate instrumentation.

Care should be taken to ensure that the positioning of the MAG generators is beyond the specified safe distances, as shown in the table below, and the required safe distance for the MAG type is observed.

Minimum clearances

MAG-02	150 mm
MAG-1	300 mm
MAG-2	400 mm
MAG-3	700 mm
MAG-4 (From each end nozzle)	1000 mm
MAG-5 MAG 5/2 (From each end nozzle)	700 mm
MAG-11...MAG-17	1500...2000 mm

Also it is important to try to, unless absolutely unavoidable, avoid positioning the generators at head height or in close proximity to egress doors nor emergency exits or areas that could lead to a dangerous situation should an unintended discharge occur.

The Pyrogen MAG generators come in two distinct types, "Mono" versions with one end plate nozzle i.e. activating from one end (these include the MAG 1, 2, 3, 5, and larger MAG 11, 12, 13, 14, 15, 16 & 17) and the "Bi-directional versions" with two end plate nozzles i.e. activating half their capability from each end (these include the MAG 4 & 5/2). If a "Mono" type MAG is to be installed, it can be fitted in such a way to direct the aerosol towards the area of considered risk. If the "Bi-directional" MAG is to be fitted, this should be fitted in the centre of the area to be protected to allow the low of aerosol over both side of the area of considered risk.

When more than one MAG generator is to be connected to the PyroSense SP-1 control Panel they should be connected in series to ensure that the control panel will monitor all generators.

See page 10-13 & 14-15 for limitations & safety instructions prior to any installation of MAG generators.

Limitations

The Pyrogen extinguishant, being a hot aerosol, has a tendency to rise upward on its release due to buoyancy forces (low specific weight compared to air). As such, the aspect of spatial distribution needs to be addressed. Therefore in order to ensure an even distribution it requires that a height limitation for the protected enclosure be set for each individual Pyrogen generators:

Height Limitations

MAG-1	1,000 mm
MAG-2	1,250 mm
AG-3	2,500 mm
MAG-4 - MAG-5	3,000 mm
MAG-11 – MAG 12	3,500 mm
MAG 13 – MAG 14	4,000 mm
MAG 15 – MAG 16m	4,500 mm
MAG-17	5,000 mm

It is important to be aware off the fact that Pyrogen requires a sealed, or as sealed as is suitable, area & that big openings in the engine room compartment will cause leakage of Pyrogen aerosol. This could, in a worst-case scenario, lead to fire not being extinguished. Therefore it is of vital importance that all hatches & ventilation fans or ducts be closed and the engine/s are stopped prior to discharge.

Typical installations

MAGS 02 - MAG 5 are attached by using the supplied bands or brackets. For “mono” type extinguishers (MAG 1, MAG 2, MAG 3 & MAG 5/1) arrange the band around the centre of the casing. For “bi” type extinguishers (MAG 4 & MAG 5/2), two bands should be used, these should be at a suitable distance from either end to allow good support and fixing. The MAG 4 has a special bracket arrangement that requires the bands to be fitted at each end of the generator. Ensure that the bands & brackets are tightened sufficiently using suitable spanners, and make sure that the unit is well held.

Mono Generator Fixings

Installation of “mono” type generator with band fixing

1. Bolt M6 & washer
2. Band
3. Pyrogen MAG Generator
4. Nut M6 & washer

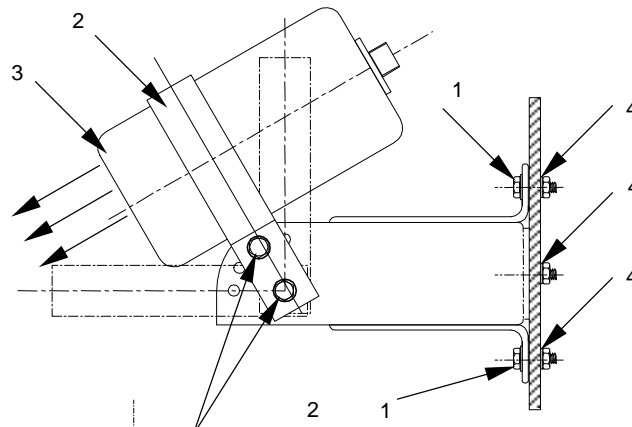

Installation of “mono” type generator with band fixing using an alternative bracket arrangement

1. Bolt M6 & washer
2. Band
3. Pyrogen MAG Generator
4. Nut M6 & washer

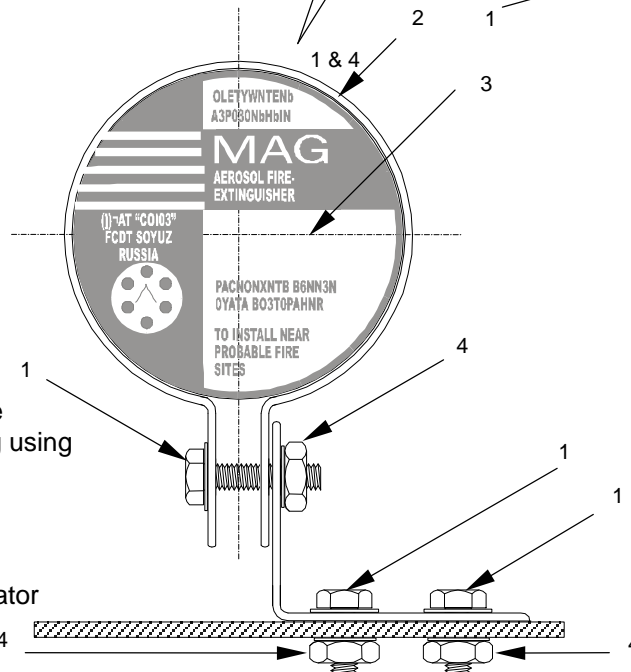

When fitting the larger MAG units (MAG 11- MAG 17) these have their own arrangement as part of the casing

Installation drawing of MAG 11 – MAG 17 generators

- 1 Fixing Bolt
- 2 Exit Diaphragm
- 3 MAG generator

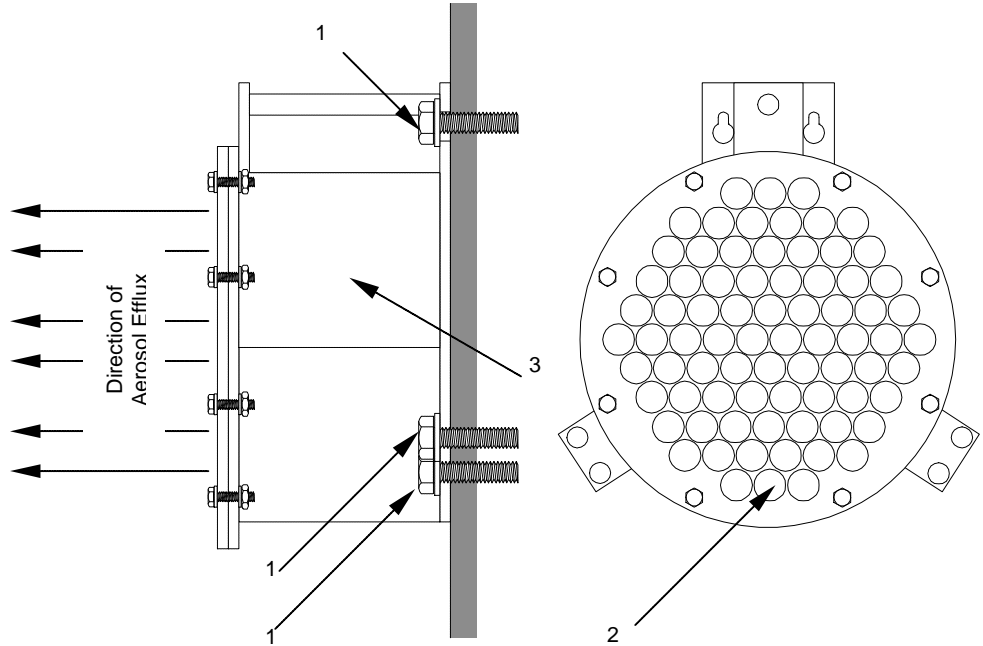

Bi-Directional Generator Fixings

Installation of MAG 4 generator with band fixing & special end brackets

- 1. M6 Bolt & Washer
- 2. M6 Nut & Washer
- 3. MAG 4 generator
- 4. Band fixings
- 5. Special end bracket

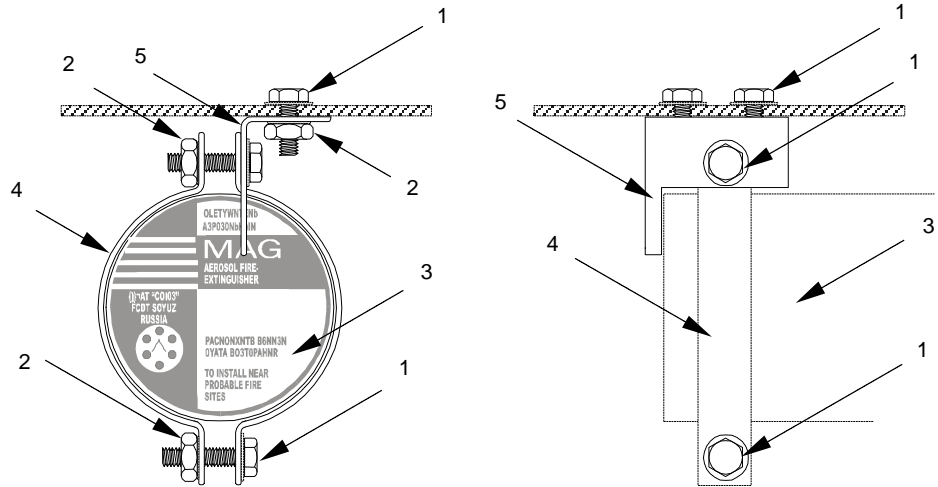

Installation of "bi-directional" type generator with band fixing

- 1. Bolt M6 & Washer
- 2. Fixing Bracket 1
- 3. Wall Plugs
- 4. M6 Bolt Nut & Washer
- 5. Pyrogen MAG Generator
- 6. Band Brackets

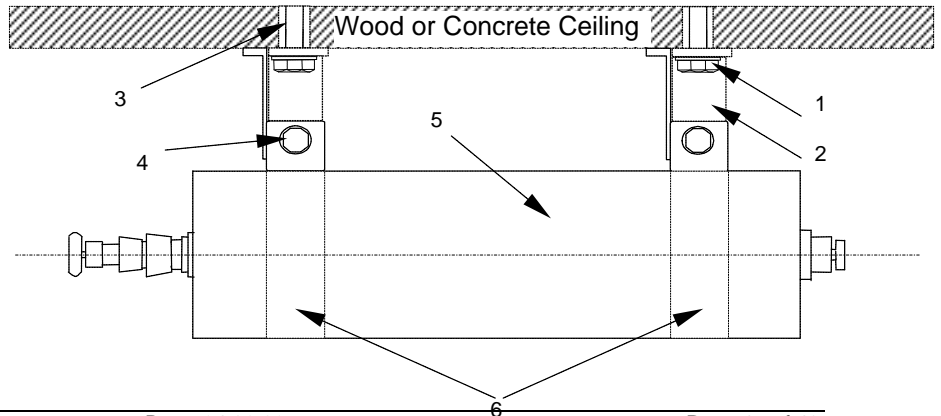

TECHNICAL SPECIFICATION PYROGEN

Pyrogen Generator

Canister Characteristics

Material	Marine Grade Aluminium
Max/Min Ambient	- 50°C ~ + 60°C
Shock	Tested to 10g for > 13,000 Impacts
Vibration	5g @ 50 ~ 250Hz
Corrosion Resistance	Greater than UL 1058
Impact Resistance	IP558
Humidity	=96%

Electrical (Thermal) Characteristics

Supervision/Monitoring Circuit	=1mA
Activation	=400mA @ 6/12/24V for 10mS
Connector	4 pin Military Type 2 PMDT Analog MIL-C-5015

Aerosol Characteristics (At Maximum Design Concentration)

Potassium Carbonates, solid	~ 7g/M3
Nitrogen Gas	~ 70% by vol.
Carbon Dioxide Gas	~ 1.2% by vol.
Carbon Monoxide Gas	~ 0.4% by vol.
Nitrogen Oxide Gas	40 – 100 ppm.
Ammonia Gas	~ 0.075% by vol.
Temp at Nozzle + 500 mm	= 75°C
Oxygen (level)	17% to 29% (typical)
Holding Time	= 60 mins

Classifications

Suitable for fires	Class A – Combustible Solids Class B – Flammable Liquids Class C – Flammable Gases Class E – Electrically Energised Fires Class F – Fats & Cooking Oils
Handling & Transport	Accordance with UN 1325 & Dangerous Goods Code 4.1 Haz. Chem. Code 2[Y] E
Packaging Group	III

Technical parameters of MAG generators

Technical parameters of the current range of MAG generators are as follows:

Parameter	MAG 02	MAG 1	MAG 2	MAG 3	MAG 4	MAG 5	MAG 5/2
Total Mass Of Generator (g)	125	650	750	1,000	4,000	2,000	2,000
Protected Volume (m ³ @ 100g per m ³)	0.20	0.60	1.0	2.0	10.0	5.0	5.0
Generator Type (Mono or Bi-Directional)	Bi	Mono	Mono	Mono	Bi	Mono	Bi
Length of Generator (mm)	120	75	90	135	375	200	300
Diameter of Generator (mm)	40	75	75	75	95	95	75
Discharge Time (s)	<3.5	<3.5	<6.0	<7.5	<10.0	<7.5	<7.5

Parameter	MAG 11	MAG 12	MAG 13	MAG 14	MAG 15	MAG 16	MAG 17
Total Mass Of Generator (g)	11,000	13,500	19,000	37,000	40,000	50,000	58,000
Protected Volume (m ³ @ 100g per m ³)	12	17	27	46	50	65	85
Generator Type (Mono or Bi-Directional)	Mono	Mono	Mono	Mono	Mono	Mono	Mono
Length of Generator (mm)	180	245	245	260	175	225	285
Diameter of Generator (mm)	245	245	305	400	490	490	490
Discharge Time (s)	<10.0	<10.0	<10.0	<10.0	<10.0	<10.0	<10.0

The control panel PyroSense SP-1

The terminals on the SP-1 are of screw/clamp type. Make sure that a suitable amount of the insulation on the cables/wires is removed and tighten down the terminal screw until the wire is securely held. It is only recommended that one conductor be placed in each terminal & that the maximum conductor size be 1.5mm²

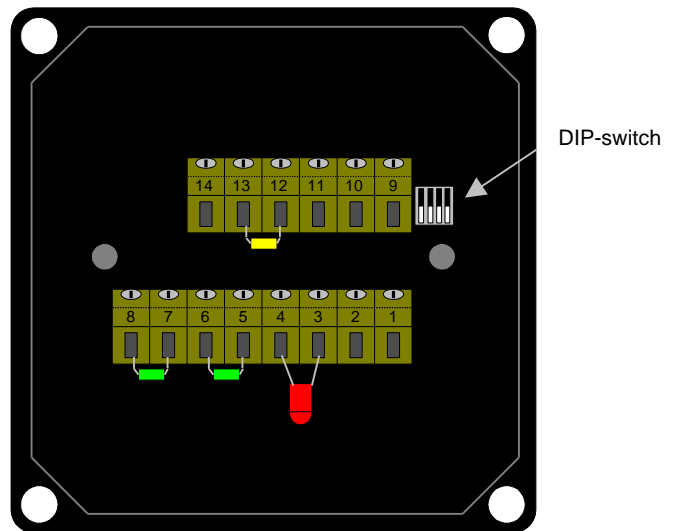

It is suggested that all out cable sheaths are removed at approximately 300mm from the ends of the cables, and only internal cores be brought to the SP-1 control panel for fixing at the terminals. All cables should be anchored via cable clips or cable tied to other cable bundles.

Terminal strip connections

- | | |
|----|--------------------------------------------|
| 1 | Battery (+) 12 or 24 V (Through a 3A fuse) |
| 2 | Battery (-) GND . |
| 3 | Pyrogen MAG generator (+) |
| 4 | Pyrogen MAG generator (-) |
| 5 | Loop 2 (+) |
| 6 | Loop 2 (GND). |
| 7 | Remote Manual Discharge Switch (+). |
| 8 | Remote Manual Discharge Switch (GND). |
| 9 | Out 1 (+) |
| 10 | Out 1 & 2 (GND) |
| 11 | Out 2 (+) |
| 12 | Loop 1 (+) |
| 13 | Loop 1 (GND). |
| 14 | Ignition + |

Conductors and cables

The conductors from the control panel to the sensor cable and to the MAG unit must be as short as possible. The conductors shall have a minimum size of 0.75mm², and the maximum length is 20 metres.

Optional accessories

Sounders and beacons should be situated in such a way that they can be easily heard, and seen, from the pilot/drivers/operators position. If required extra sounders and beacons may be added in so that it is possible to hear and see them from all locations. It is also possible to connect existing sounders and/or beacons to the control panel to (see diagram on page 42).

NOTE! Ensure that all Beacons and Sounders are visible & audible from all areas.

The sensor cable

The Thermal Sensing cable is supplied complete with the End Of Line (EOL) resistor required, and only needs to be connected at one end.

When installing the cable in the area to be protected it is important to install the cable at a point where possible fire risks may occur, and that any heat produced in the event of a fire can reach the as greater amount of the circumference of the cable as is possible. When installing, & while considering the best routing of the cable, be careful to ensure that it is not too close to high running temperature items like exhaust manifolds etc. as this cable will activate at temperatures above 180°C.

The Thermal Sensing cable can be secured with the cable ties provided, however caution should be taken to ensure that these are not over tightened as this may cause the cable to short and give spurious indications.

Caution! Ensure that, while the Thermal Sensing cable is securely fixed it is not over tightened.

Setting the programming DIP-switch

“Cause effect” matrix

<div style="background-color: yellow; padding: 5px;"> <p>1 = ON, 0 = OFF, X = No Effect</p> <p>Factory default = all switches off</p> </div>	DIP SW.				Buzzer Continuous	Buzzer Intermittent	Out. 1 Continuous	Out. 1 Intermittent	Out. 2	Delayed Discharge	Mom. Discharge	Alarm LED	Activation Confirmed LED	Fault LED	NOTE
	4	3	2	1											
Loop 1 = ALARM	X	X	1	0		○		○	○	○			○		1
Loop 2 = ALARM	1	0	X	X		○		○	○	○			○		2
Loop 1 & 2 = ALARM	1	1	1	1		○		○	○	○		○	○		3
Loop 1 = ALARM	X	X	0	0	○		○					○			4
Loop 2 = ALARM	0	0	X	X	○		○					○			5
Loop 1 = ALARM	X	X	0	1		○		○				○	○		6
Loop 2 = ALARM	0	1	X	X		○		○				○	○		7
Manual discharge by front buttons	X	X	X	X		○		○	○		○		○		8
Remote Manual Discharge=ALARM	X	X	X	X		○		○	○		○		○		9
Loop 1 = FAULT (Break in the cable loop)	X	X	X	X	○		○							○	10
Loop 2 = FAULT (Break or shorted loop)	X	X	X	X	○		○							○	11
Remote Manual Discharge = FAULT (Break or shorted loop)	X	X	X	X	○		○							○	12
MAG loop = FAULT (Break in the cable loop)	X	X	X	X	○		○							○	13
○	Indicating an alarm situation														
○	Indicating activating of the MAG generator (discharge)														
○	Indicating confirmed activating of the MAG generator														
○	Indicating a fault situation														

The DIP switches can be changed and set by using a pen or something of similar size. Once the DIP switches are set, they can be sealed using the enclosed sealant.

Programming table Comments

1. The Alarm loop 1 can be used to initiate a delayed (20 sc.) activation of the Pyrogen MAG generator. Sensors can either be of linear heat line detector or a spot detector (heat, UV/IR or smoke types) types. The EOL resistor required is 47kO. The alarm condition is a shorted loop. If the loop is broken a "Fault" will be indicated. The alarm contacts must be set in a normally open (NO) position.
2. The Alarm loop 2 can be used to initiate a delayed (20 sc.) activation of the Pyrogen MAG generator. Sensors can either be of linear heat line detector or a spot detector (heat, UV/IR or smoke types) types of voltages free contact type (NC). The EOL resistor required is 47kO in series and a 47kO in parallel to the NC contact of detector and the other resistor. Alarm condition is a 47kO input (open contact of sensor).
If the loop is broken or short circuit "Fault" will be indicated. The normal situation is a loop resistance of 23,5kO.
3. A combination of Alarm loop 1 and Alarm loop 2 can be used to initiate a delayed (20 sc.) activation of the Pyrogen MAG generator.
4. The Alarm loop 1 can be used to initiate an Alarm situation (fire alarm, pressure switch monitoring etc.).
The sensors might be one or more spot detectors, CO or propane detectors, water leakage detector etc. The loop must be terminated with an EOL resistor of 47kO. Alarm condition is a shorted loop. If the loop is broken "Fault" will be indicated. The alarm contacts must be set in a normally open (NO) position.
5. The Alarm loop 2 can be used to initiate an Alarm situation (fire alarm, pressure switch monitoring etc.).
Sensors could either be a linear heat line detector or a spot detector (heat, UV/IR or smoke types) of voltages free contact type (NC). EOL resistor is a 47kO in series and a 47kO in parallel to the NC contact of detector and the other resistor. Alarm condition is a 47kO input (open contact of sensor).
If the loop is broken or short circuit "Fault" will be indicated. The normal situation is a loop resistance of 23,5kO.
6. The Alarm loop 1 can be used to monitor the Pyrogen MAG generator for pyrotechnical activation (confirmed activation).
The sensor might be a Thermal Sensing cable or a Thermal Bi-metallic switch. The loop must be terminated with an EOL resistor of 47kO. Alarm condition is a shorted loop. If the loop is broken "Fault" will be indicated. The alarm contacts must be put in a normally open (NO) position.
7. The Alarm loop 2 can be used to monitor the Pyrogen MAG generator for pyrotechnical activation (confirmed activation).
The sensor might be a Thermal Bi-metallic switch or a melting fuse type.
EOL resistor is a 47 kO in series and a 47 kO in parallel to the NC contact of detector and the other resistor. Alarm condition is a 47kO input (open contact of sensor).
If the loop is broken or short circuit "Fault" will be indicated. The normal situation is a loop resistance of 23,5kO.
8. By simultaneously pressing the push buttons marked "Press" on the control panel, the Pyrogen MAG generator will be discharged. An intermittent warning sound on internal buzzer or external sounder indicates that the MAG generator is about to be discharged. If the buttons are released during the 5-second period the MAG units will not discharge. After approx. 5 seconds with both buttons depressed simultaneously the intermittent alarm will be transferred to a continuous tone and the MAG unit will be discharged. The indicator "Activated" will be illuminated.
9. By activating a remote manual discharge button (if any) the MAG generator will discharge. The indicator "Activated" will be illuminated.
10. Fault condition Alarm loop 1. "Fault" condition is initiated by a break in the loop.
11. Fault condition Alarm loop 2. Either a break in the loop or a short initiates "Fault" condition.
12. Fault condition External discharge button. Either a break in the loop or a short initiates "Fault" condition.
13. Fault condition MAG input loop. "Fault" condition is initiated by a break in the loop.

Software priorities

More serious events always take priority over less serious events. Thus, if a rule calling for immediate discharge is activated, then it has first priority, followed by delayed initiation, followed by the various warning and alarm indicators.

Power LED

The power LED will be on constantly if the ignition in input indicates that the ignition is on.

Activated LED

The discharge LED has three separate and distinct speeds that it flashes at to show various stages of the discharge cycle. In the first 17 seconds, of the overall 20-second delay, it will flash at a slow regular rate. After the first 17 seconds and for the last three seconds of the delay the flashing speed will increase. Once the 20-second delay has finished and the Pyrogen MAG are discharging the LED will flash at its fastest rate.

If a Manual and immediate discharge is chosen the LED will go straight to flashing at the highest rate.

Test functions

General		
<p>The system has a comprehensive test mode that can be entered by holding down the silence button during power on. This test mode is designed to allow all the inputs and outputs to be fully tested as part of the production and testing of the panels, and optionally during installation and service. The testing is divided into three stages, with the reset button used to step between the stages (giving a short audible buzz as acknowledgement). After stage 3 is complete, pressing reset will re-start the system in normal mode. The DIPswitches and the LEDs are used extensively during test mode.</p> <p>The LEDs and buzzer are tested while the silence button is being held down during start up, as is the silence button itself. The reset button is tested when stepping between the stages.</p>		
Stage 1 – Testing the LEDs		
<p>At this stage, the four DIPswitches are connected to four of the LEDs. When the corresponding switch is activated, the appropriate LED will blink between the main and reserve elements.</p>	DIP switch	LED
	4321 xxx1	Power LED
	xx1x	Fault LED
	x1xx	Activation LED
	1xxx	Alarm LED
Stage 2 – Testing the analogue inputs		
<p>When testing the analogue inputs, one input is chosen at a time using the DIPswitches, as shown. The input will be analysed, and the state (short, closed, open, free or error) will be determined and shown on the LEDs. The test mode distinguishes between a “tight” match and a “normal” match. A tight match uses tighter boundaries, and is useful during testing, while the normal match is used during normal operation. Tight matches cause the corresponding main LED element to light, while normal matches light the reserve element.</p>	DIP switch	LED
	4321 0001	Alarm loop 2
	0010	Alarm loop 1
	0100	Man. Activation
	1000	MAG loop
	SHORT CLOSED OPEN FREE ERROR	Power LED Fault LED Alarm LED Activation LED No LED
Stage 3 – Testing the outputs and remaining inputs		
<p>In the final test stage, the DIPswitches and buttons are used to activate the outputs and to check the inputs, as shown.</p>	DIP /input	LED/Output
	Ignition activated	Power LED
	4321 xxx1	Fault LED/shutdown
	1x1x	Activation. LED/MAG Activation.
	x1xx	Alarm LED/Alarm out

Trouble shooting

General

If a "Fault" is indicated at the control panel, the following procedure should be followed to locate the problem

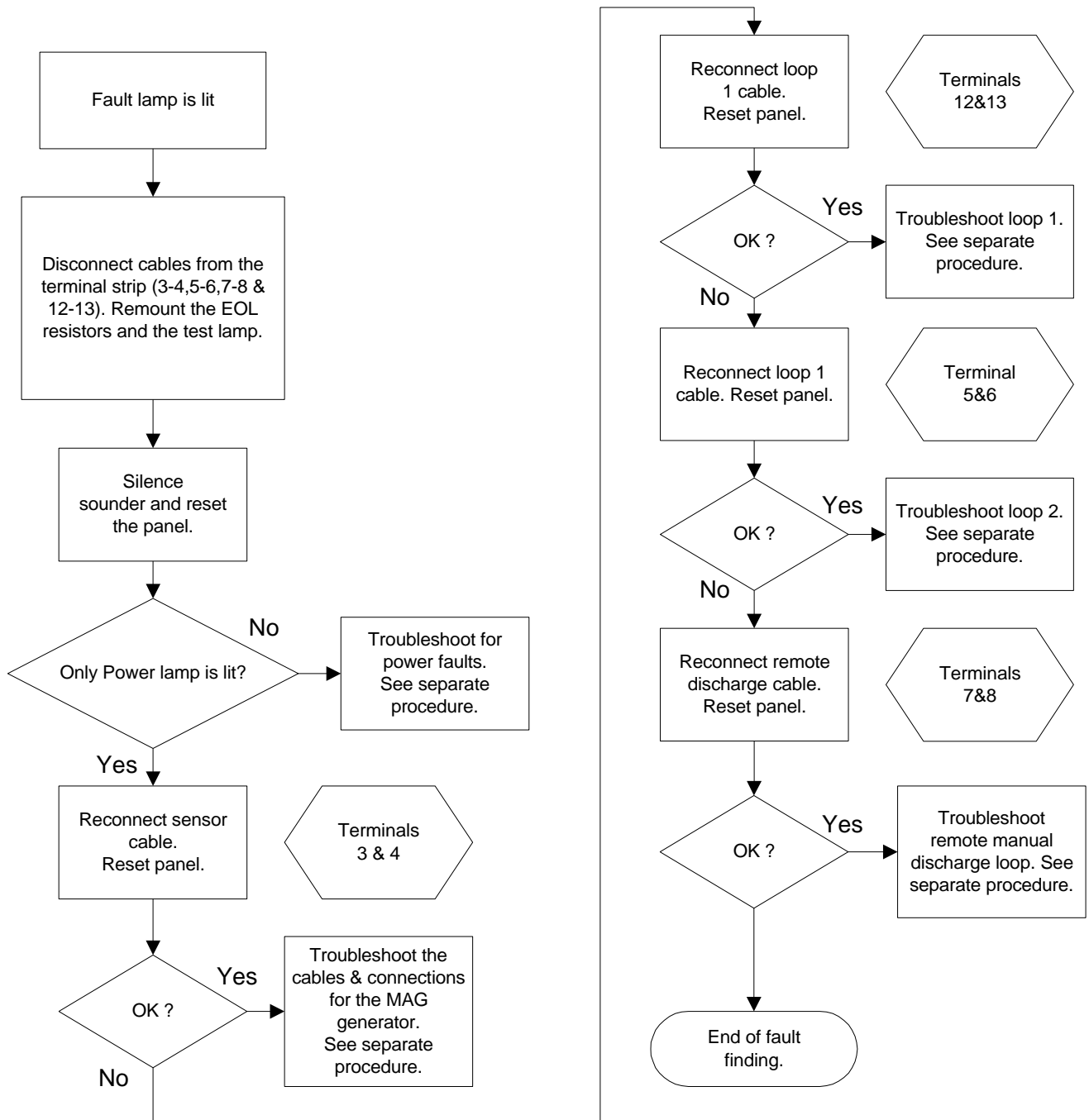

No light in the Power lamp

- Check cables and connections.
- Make sure that the ignition is switched on and that +ve from the ignition switch is connected to the panel.
- Check that +12/24VDC is connected to the control panel (use a test lamp or multi-meter).

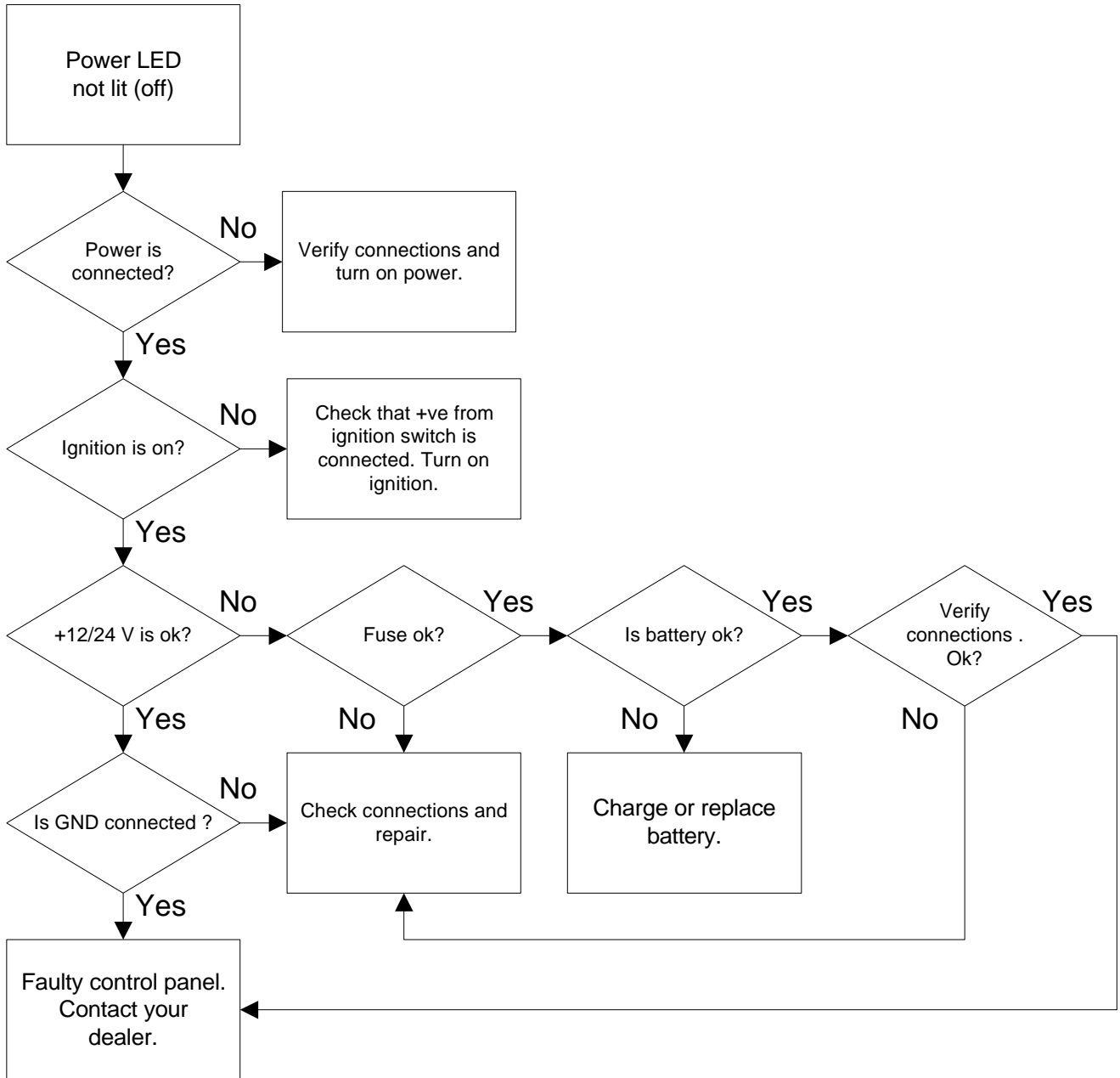

Fault LED is lit.

Check MAG Generator

Verify connections and cables for the MAG generator.

Disconnect the wires from terminal 3 & 4 and measure the loop resistance (correct value is 2.5-4.5Ω) ?

It is important that if you intend to check the resistance of the Pyrogen MAG generators you should use a **digital** multi-meter. The maximum test current shall not exceed 50 milliamps for a period of 5 minutes. The monitoring current shall not exceed 5 milliamps.

A check should also be made to the generator cable in the junction box and finally measure directly on the generator connection (pin 1 & 2).

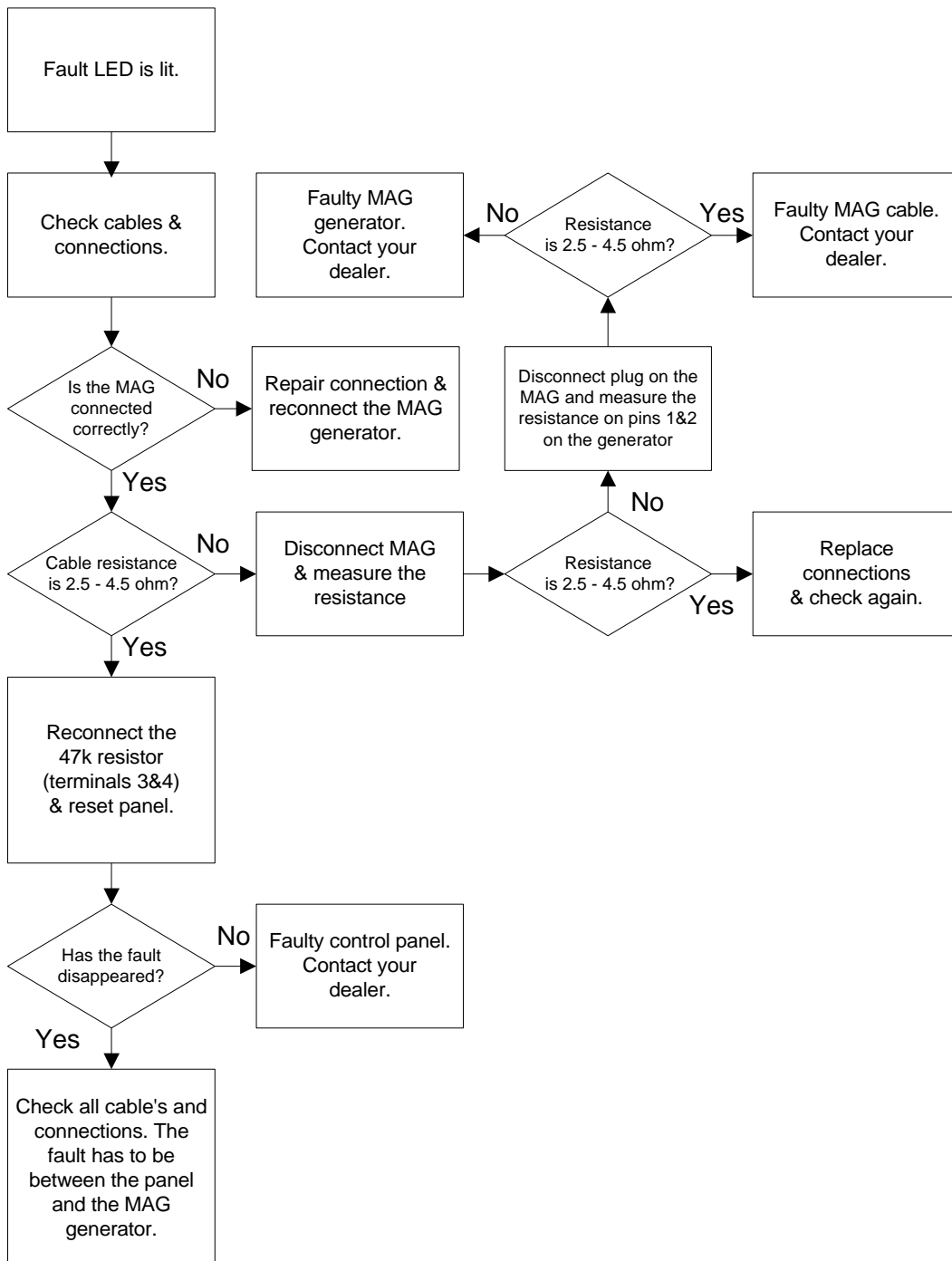

The Fault LED is lit

Check loop 1 – Sensor cable

If a sensor cable is not connected, check that the 47 kΩ resistor is connected at terminal 12 & 13 (yellow).

A digital multi-meter is to be used to measure the loop resistance. Correct value is 47 kΩ .

A check should also be made to measure the cables connected in the junction box.

Troubleshooting procedure – sensor cable

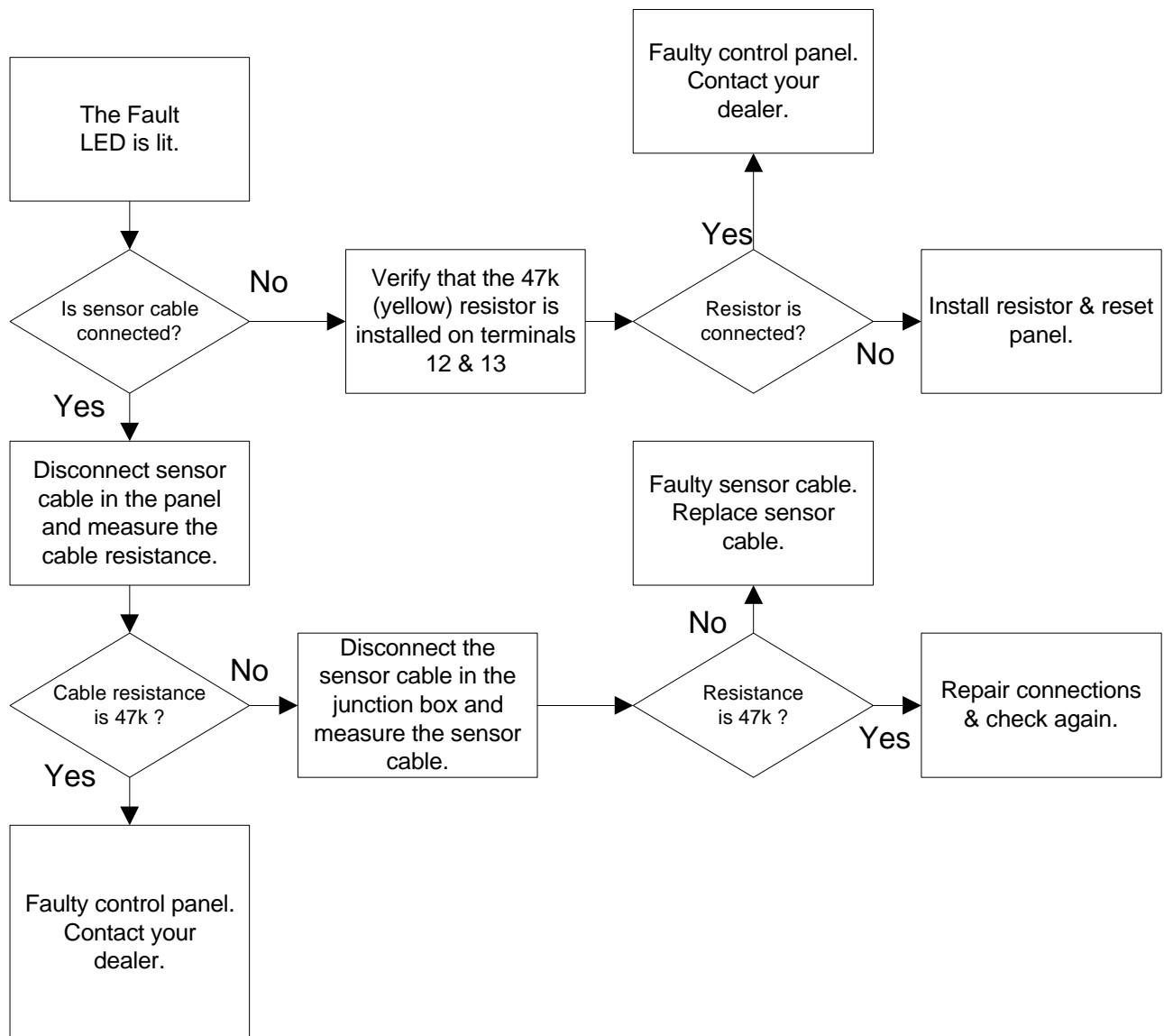

Fault LED is lit

Check loop 2 – Alarm detector(s)

If external detectors are not connected, check that the 22 kΩ resistor is connected at the terminals 5 & 6 (Green).

Check that a detector is connected to loop 2 (terminal 5 & 6), and that the EOL resistors is correct installed in the detector.

A digital multi-meter is used to measure the loop resistance. Correct value is 23,5 kΩ .

A check should also be made to measure the cables connected in the junction box and in the detector.

Troubleshooting procedure – Loop 2

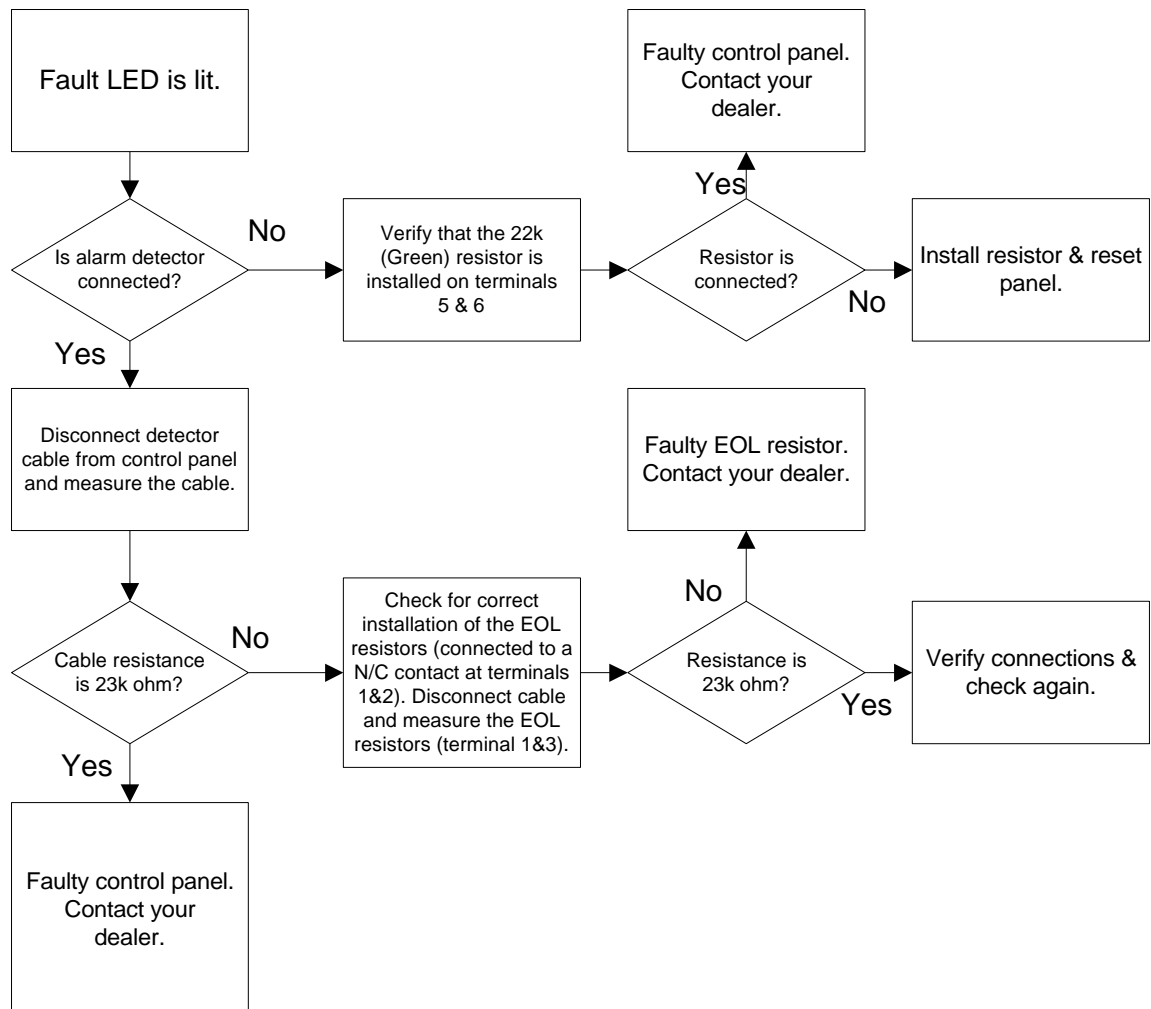

Fault LED is lit

Check external manual discharge loop

If a remote manual discharge button is not connected, check that the 22 kΩ resistor is connected at terminals 7 & 8 (Green).

If there is a remote discharge button connected check that it is connected correctly to terminals 7 & 8, and that the EOL resistor is correctly installed in the discharge button.

A digital multi-meter is used to measure the loop resistance. Correct value is 23,5 kΩ .

A check should also be made to measure the cables connected in the junction box.

Troubleshooting procedure – manual discharge

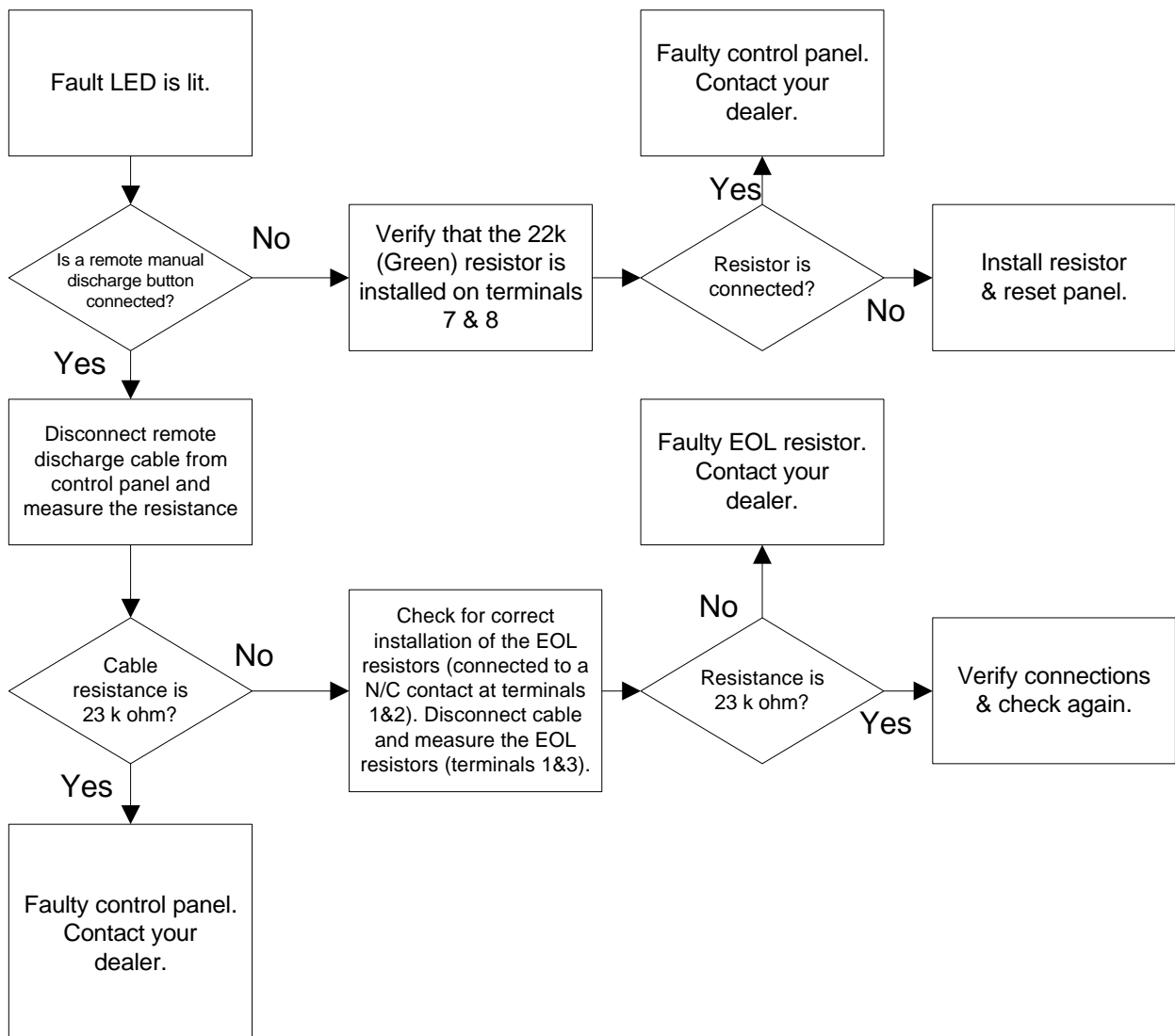

Alarm LED is lit

The following situations will cause the “Alarm” Led to lit:

- The Thermal sensing cable connected to loop 1 has a short.
- A short on any cable connected to loop 1.
- A detector connected to loop 2 is in alarm condition.
- The incorrect resistor is fitted at terminals 5 & 6 (Yellow instead of Green).

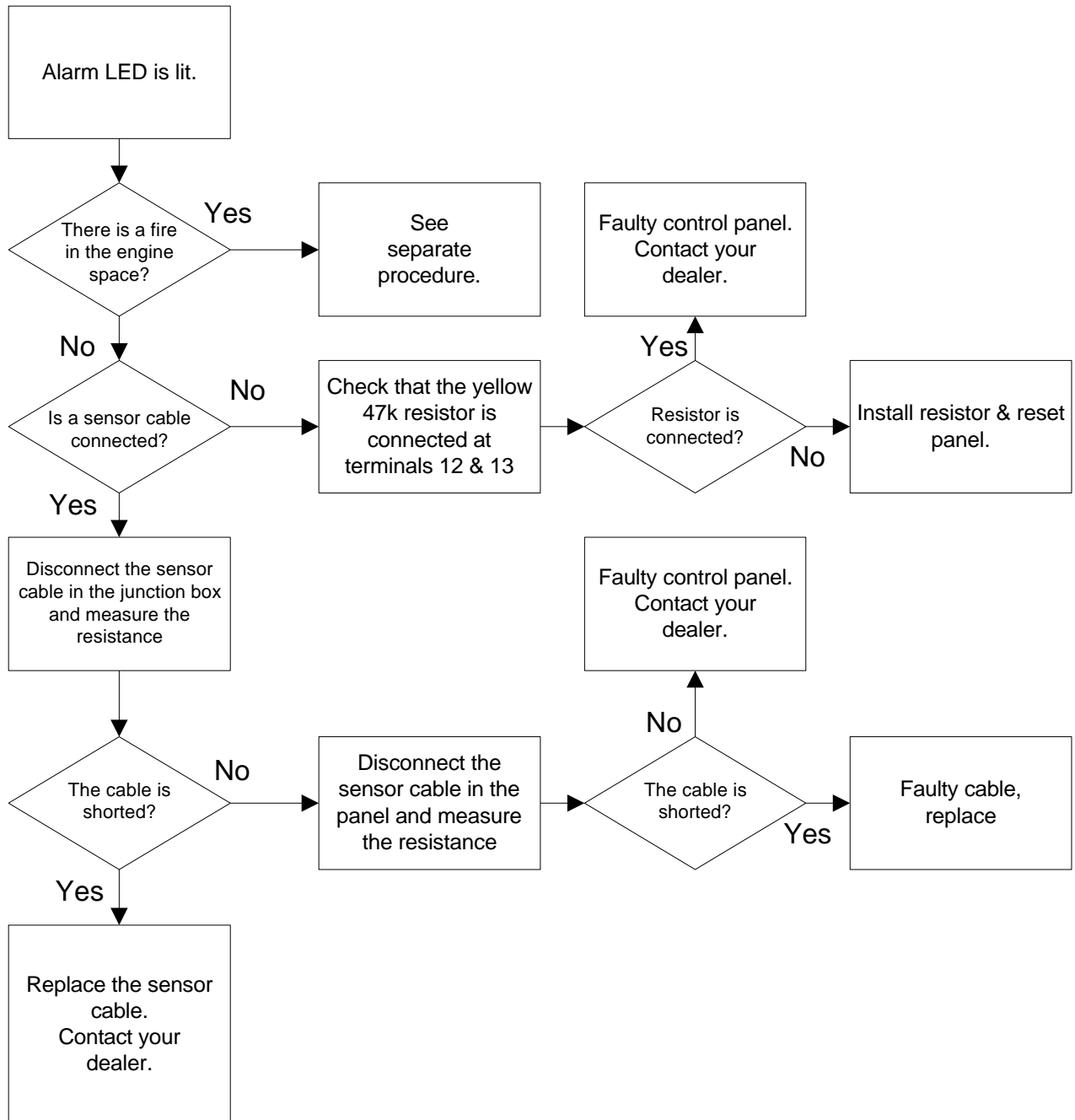

Alarm + Activated LED is lit

The following situations causes the Alarm & Activated LED's to light:

- Alarm detector or sensor cable connected to loop 1 is in an alarm condition and the loop is programmed to monitor the Pyrogen MAG generators for pyrotechnical discharge. See the DIP-switch settings on page 19.
- Alarm detector connected to loop 2 is in an alarm condition and the loop is programmed to monitor the Pyrogen MAG generators for pyrotechnical discharge. See DIP -switch settings on page 19.
- Terminals 12 & 13 are shorted and the loop is programmed to monitor the Pyrogen MAG generators for pyrotechnical discharge. See DIP-switch settings on page 19.
- The incorrect resistor is installed at terminals 5 & 6 (Yellow instead of Green) and the loop is programmed to monitor the Pyrogen MAG generators for pyrotechnical discharge. See DIP-switch settings on page 19.

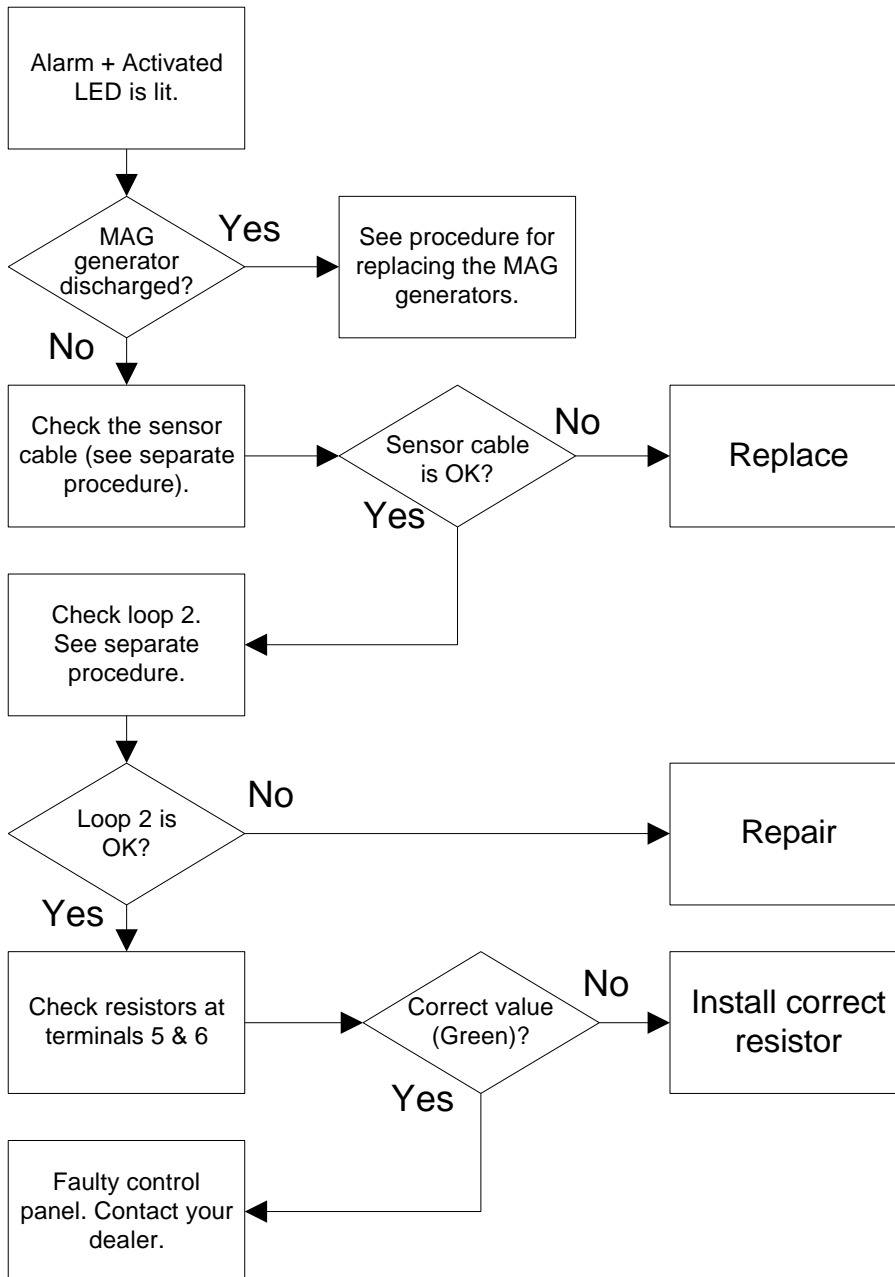

List of delivered items

Included in the PyroSense SP-1 basic kit:

Quantity	Description
1	Control panel (SP-1)
1	Junction box (ELE-1242802)
15m	Flame retardant cable (Radox 125 FR 2x0,75),
1	Installation & user manual (TEC-DOC-BOAT-M)
1	Area warning sign - marine (SPE-PYR-1)
1	Area warning sign - service (SPE-PYR-2)
1	Installation & fixing equipment (PYR-FESTEMAT.)

In addition a Pyrogen MAG-generator suitable for the area (V) of the protected space, has to be added.

	<p>TEC-BÅT-SP1-06 Dim. Ø75x 75 mm Weight 0.65 kg Discharge type: Mono</p>	<p>Maximum protected volume 0.6 m³ MAG 1 c/w fixing bands & brackets Cable with electrical connector (2m)</p>
	<p>TEC-BÅT- SP1-01 Dim. Ø75x 90 mm Weight 0.75 kg Discharge type: Mono</p>	<p>Maximum protected volume 1 m³ MAG 2 c/w fixing bands & brackets Cable with electrical connector (2m)</p>
	<p>TEC-BÅT- SP1-02 Dim. Ø75x 135 mm Weight 1.0 kg Discharge type: Mono</p>	<p>Maximum protected volume 2 m³ MAG 3 c/w fixing bands & brackets Cable with electrical connector (2m)</p>
	<p>TEC-BÅT- SP1-05 Dim. Ø95x 135 mm Weight 2.2 kg Discharge type: Mono (MAG 5/2 Bi-directional)</p>	<p>Maximum protected volume 5 m³ MAG 5 c/w fixing bands & brackets Cable with electrical connector (2m)</p>
	<p>TEC-BÅT- SP1-10 Dim. Ø95x 375 mm Weight 4.0 kg Discharge type: Bi-directional</p>	<p>Maximum protected volume 10 m³ MAG 4 c/w fixing bands & brackets Cable with electrical connector (2m)</p>

Optional equipment

It is possible to have various types of sensors connected to the control panel. This could be thermal sensing cables, spot detectors (heat & smoke), CO or propane detectors, water leakage detectors etc. The SP-1 can be programmed for automatic activation of MAG generators if need be. Further more there is a wide range of external sounders, and beacons and remote manual discharge buttons that can be connected.

Accessories and spare parts

Description	Specification	Stock number
Sensor cable with EOL resistor 47kO (Alarm temp.180°C)	4 meter	PYRH8069-4M
Sensor cable without EOL resistor	per meter	PYRH8069-1M
EOL resistor 47kO for sensor cable	47kO	PYRV009
EOL resistor end cap for sensor cable		PYRV010
Adhesive warning sign - marine		SPE-PYR-1
Adhesive warning sign - service		SPE-PYR-2
Flash beacon Red. Voltage 24 V dc. IP65	Ø93 x155mm	HOL-101.272
Flash beacon + Sounder Voltage 18-30 V dc. IP 65		HOL-101.275
Sounder 9-28 V dc, 20mA IP65, 103 Db		HOL-06.133
Flash beacon Voltage 5-15 V dc. IP 67		HOL-06.230
Sounder + Flash. Voltage 10-14 V dc. For indoor use only		HOL-06.
Buzzer (100db). Voltage 9-28 V dc. IP65		HOL-06.125
Buzzer (100db). Voltage 9-28 V dc. IP65		HOL-06.126
Pyrogen MAG-generator MAG 1		PYRMAG1
Pyrogen MAG- generator MAG 2		PYRMAG2
Pyrogen MAG- generator MAG 3		PYRMAG3
Pyrogen MAG- generator MAG 4		PYRMAG4
Pyrogen MAG- generator MAG 5		PYRMAG5
Pyrogen MAG- generator MAG 5/2		PYRMAG5/2
Fastening equipment, Kit SP-1		PYR-FESTEMAT
Cable Radox 125 FR 2x0,75/ flame retardent	per meter	HUS506492
6 pole junction box IP55		ELE-1242802
SP-1 control panel		WEC-SP1-1
Electrical connector for MAG1,2&3		PYRF030
Electrical connector for MAG1 MAG 4&5		PYRF030-1
Electrical connector for MAG1 MAG1,2&3 with cable	2 meter	PYRF030-CABLE
Electrical connector for MAG1 MAG 4&5 with cable	2 meter	PYRF030-1-CABLE
Bands & bracket for MAG 1,2&3		PYR022
Bands & bracket for MAG 4&5		PYR025
Pyrotechnical activation cord (fuse)	1 meter	PYRPYAF1M
Smoke detector optical, 12 V dc with relay (Nc-Com-No)		HOL-13.074
Smoke detector ionic, 12 V dc with relay (Nc-Com-No)		HOL-13.092
Heat detector bimetallic Alarm temp. 58°C. Normally closed		HOL-13.106
Heat detector bimetallic Alarm temp. 85°C. Normally open		HOL-13.107
Gas detector, 12 V dc		HOL-13.915
Manual discharge button, indoor use only		HOL-13.832
Manual discharge button, IP55		KAC-WY7/2001
Water leakage detector. 9-15 Vdc with relay (Nc-Com-No)		HOL-14.330
Protecting cap for the above water leakage detector		HOL-14.331
System Sensor optical smoke detector head	2151E	HOL-103.422
System Sensor heat detector head, 58°Rate of rise (24Vdc only)	5451E	HOL-5451E
System Sensor heat detector head, 78°(24Vdc only)		ESM-4451E
System sensor detector base, 12 & 24 V dc	B424RL	HOL-103.419
EOL resistors for connecting NC alarm contacts to the SP-1	Loop 2 & man.d	WC-EOL-2x47kohm

Thermal activation

Thermal activation of the Pyrogen MAG-generator is provided by action of an inbuilt thermal ignition device & a linear thermal activation cord, which automatically ignites at =175° C or when exposed to a naked flame and propagates ignition to the solid aerosol-forming composition.

Do not crush the cord at any point and ensure that there is no possible risk of mechanical damage. The cord can be mounted by use of cable bands fixed with self-tapping screws. Ensure that the cord is not bent tightly at any point; a permissible bend is no less than 15mm radius.

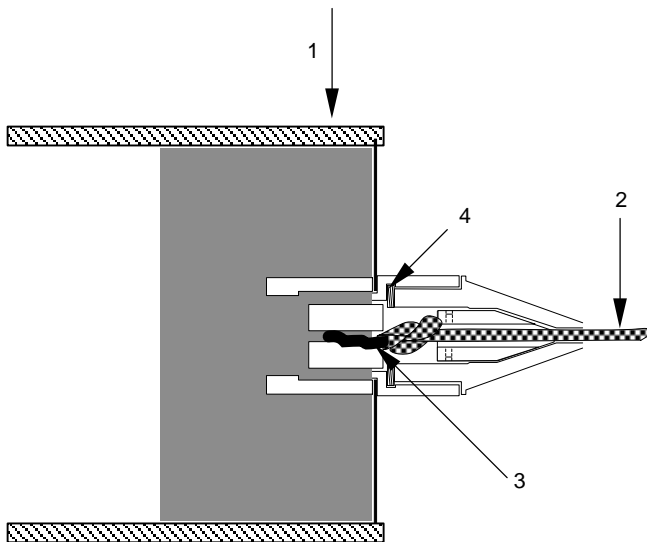
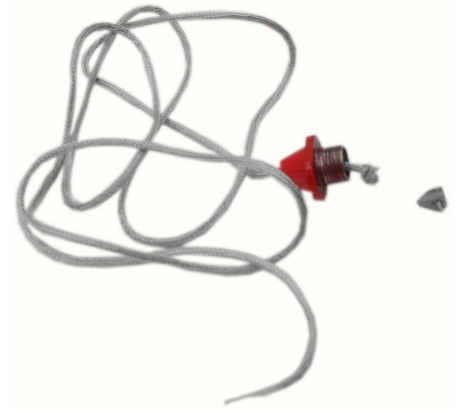

Typical drawing showing connection of thermal activation cord

1. MAG-generator
2. Thermal activation cord
3. Thermal activation cord exposed from protective braiding
4. Area for selant

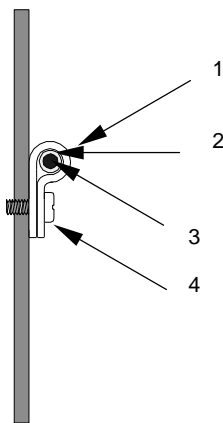

Typical drawing showing connection of thermal activation cord with the supplied bands

1. Band
2. Protected braiding
3. Thermal activation cord
4. Self tapping screws

Note: When installing, & while considering the best routing of the Thermal Activation cord, be careful to ensure that it is not too close to high running temperature items like exhaust manifolds etc.

Technical data PyroSense SP-1

Power supply	Operating voltage.....	8 - 28 VDC
	Standby current (8 – 28 VDC).....	2 mA (ignition off)
	Normal current.....	50 mA
	Internal automatic fuse.....	2 A
	Fuse on supply lead (max).....	5 A
Ignition	From ignition- or main switch	+ 8 to 28 VDC (2 mA)
Alarm loop 1 (Thermal sensing cable)	Alarm Temperature	180°C
	Maximum normal ambient temp.....	105°C
	Voltage.....	3 VDC
	Normal current/Alarm current	0.03 / 0.06 mA
	Sensor cabel EOL resistor.	47 kΩ
Alarm loop 2	Alarm situation, resistor value on loop	23,5kΩ
	Norm. situation, resistor value on loop.	47kΩ
	EOL resistors on NC alarm contact ...	2x47 kΩ ¹
	Voltage.....	3 VDC
	Normal current/Alarm current.....	0.03/ 0.12 mA
Remote manual discharge loop	Alarm situation, resistor value on loop	23,5kΩ
	Norm. situation, resistor value on loop.	47kΩ
	EOL resistors on NC alarm contact ...	2x47 kΩ ²
	Voltage	3 VDC
	Normal current/Alarm current.....	0,03/ 0,12 mA
Discharge signal	Duration (Pulse time).....	10 sec.
	Voltage	8 - 28 VDC
	Discharge current (Max).....	1,2 A (current limitation)
	Normal current 12V/24V	0.25 / 0.5 mA
	Max number of MAG generators....	2 (12 V dc) or 4 (24 V dc)
Discharge monitoring	Voltage	3.3 V dc
	Current.....	0.1 mA
Sounder/Beacon connection (Output 1)	Voltage	8 - 28 V dc
	Current (max)	1.8 A ³
Engine & ventilation shut down (Output 2)	Voltage	8 - 28 V dc
	Current (max)	1.8 A ³
Dimensions	Front L x W x D.....	70 x 70 x 30 mm
	Cut out.....	Ø 60 mm
	Depth in cut out	40 mm
	Weight.....	200 g
IP Rating	Flush & surface mounted	IP65 (IP67 on request)
Limited life components	MAG generator.....	Max. 10 year ⁴

The manufacturer reserves the right to amend specifications and details within this document, without prior notice.

¹ R1=47k in serial with NC alarm contact, and R2=47k in parallel with the NC alarm contact and R1.

² R1=47k in serial with NC alarm contact, and R2=47k in parallell with the NC alarm contact and R1.

³ Max. same time load for the out 1 & out 2 are 2 Amp.

⁴ Depending upon environmental exposition, the MAG cannister life time is guaranteed from 1 to 10 years.

Installation check list

- The control panel is located in an easily accessible location.....
- The power is properly connected to the battery.....
- All sensor & detector cables are properly connected.....
- All discharge cables is properly connected.....
- Area Warning signs are fitted in visible locations.....

Disconnect the cables to the Pyrogen MAG-generator/s connect the power to the control panel and switch on the ignition.

- The "Power" LED illuminates.....
- "Fault" is indicated at the panel.....
- Short the sensor cable terminals in the junction box.....
- The alarm LED illuminates and the buzzer sounds.....

Reset the panel

- Disconnect the detector cable at loop 2
- The Fault LED illuminates and the buzzer sounds
- Re-connect the detector cable and reset the panel
- Activate the alarm detector by disconnecting the NC alarm contact
- The alarm LED illuminates and the buzzer sounds
- Re-connect the alarm contact cable and reset the panel

Connect a test lamp (12-24 V 2W) to the MAG generator connector & reset the panel.

- Simulate a discharge
(Press both discharge buttons, simultaneously, on the front of the control panel for 5 seconds)
- The test lamp illuminates after a 5 second delay
- Disconnect the power an re-connect the MAG cables

Connect the power to the control panel and switch on the ignition,

- Only the Power LED is lit

Personal statement

The MAG generator has been re-connected after performing the above tests

Distributor: _____ Phone: _____

Installer: _____ Phone: _____

Date of installation: _____

The system functions properly without any faults:

Place

Date

Sign.

Installation LOG

Please complete the following list of purchasing & Installation details.
All future altering of the system settings, adding of auxiliary equipment, any faults etc. has to be recorded in the Service Log.

Date of purchasing: _____

Casing Serial Number SP-1: _____

Casing Serial Number MAG generator: _____

Name & Adress of distributor: _____

Date of installation: _____

Setting of DIP-switch

Factory default:

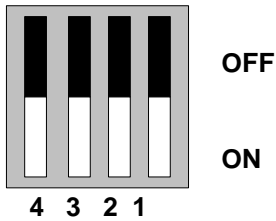

Installation settings:

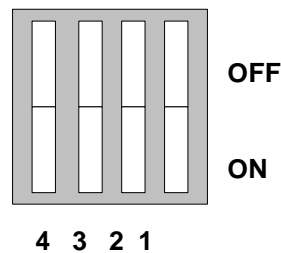

Shade each DIP-switch to show actual setting

Sensor/Detector connected to Loop 1: _____

Sensor/Detector connected to Loop 2: _____

Connected Manual Discharge button: _____

Connected equipment to Out 1: _____

Connected equipment to Out 2: _____

Number & type of connected MAGs: _____

Certificate of conformity

The PyroSense SP-1 meets the following requirements & directives:

BASIC STANDARDS

EN55022, EN6100-3-2, EN50130-4, EN61000-4-6, EN61000-4-3, EN61000-4-4, EN61000-4-2, EN61000-4-5 og EN61000-4-11

GENERIC STANDARDS

Emission: EN 50081-1
immunity: EN 50082-1

Prepared & developed in harmony with:

NES 814 Issue 1
Requirements For Determining the Shock Strength of Equipment

59-41 (Part3) Supplement D/Issue 5
Test Method DRE01. Radiated emission E field 14kHz - 18 GHz

59-41 (Part3) Supplement F/Issue 5
Test Method DRE02. H field Radiaton 20Hz - 50 kHz

59-41 (Part3) Supplement F/Issue 5
Test Method DRE03. Radiated emission Installed antenna 1.6Mhz - 76 Mhz

EN 54-1 (Fire detection and fire alarm systems - Part 1
EN 54-2 (Fire detection and fire alarm systems - Part 2
CEN/TC 191 (fixed firefighting systems) prEN 12094-1 - DRAFT

Instrument: Fire & Extinguishing control device
Category: Electronic Control Device (ECD)
Type: PyroSense SP-1
Manufacturer: Westcontrol AS

 The product meet the requirement of 89/336/EEC (EMC Directive)

Installation diagram Basic Kit

One-line diagram

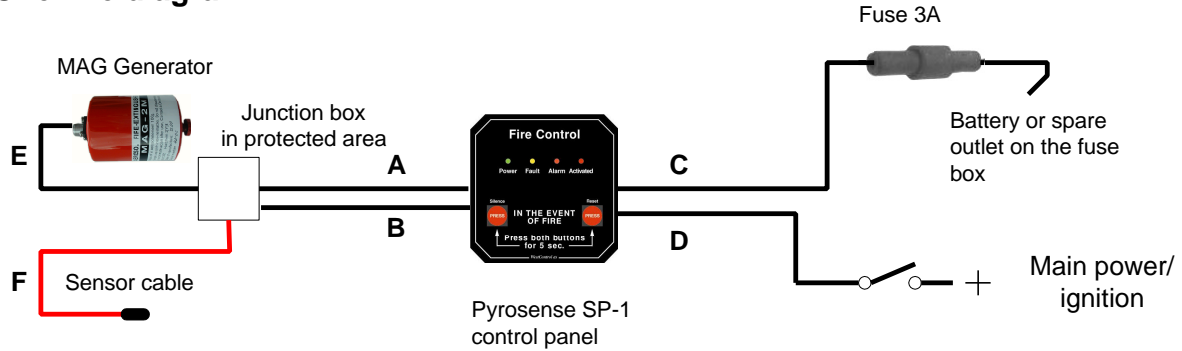

Cabel references

- A - Connection of the MAG Generator to the PyroSense SP-1 Control Panel. Item No. HUS506492
- B - Connection of the Thermal sensing Cable to the PyroSense SP-1 Control Panel. Item No. HUS506492
- C - Connection of the battery to the PyroSense SP-1 Control Panel (2x1mm² stranded).
- D - Connection of the Ignition/Main Power to the PyroSense SP-1 Control Panel (1x0,75mm²)
- E - MAG Generator Flying Lead from the Junction Box to the MAG
- F - Thermal Sensing cable c/w EOL resistor (length 4metres).

Installation diagram

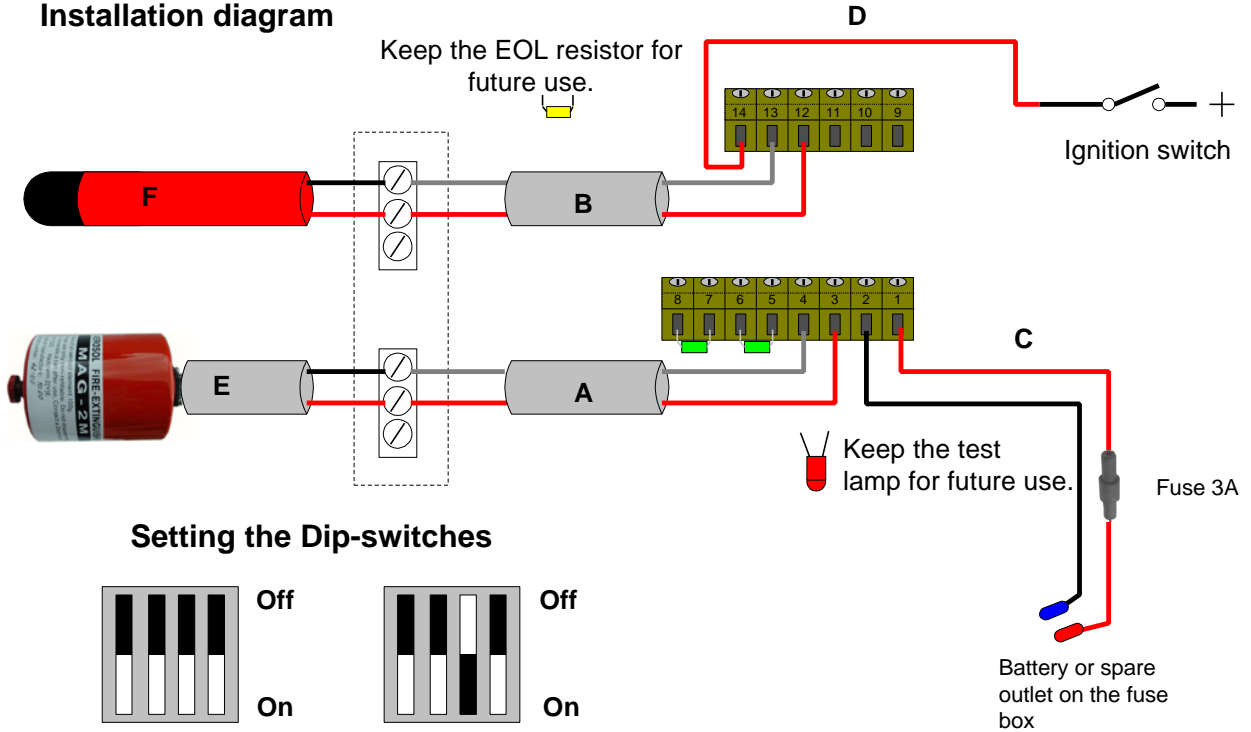

Setting the Dip-switches

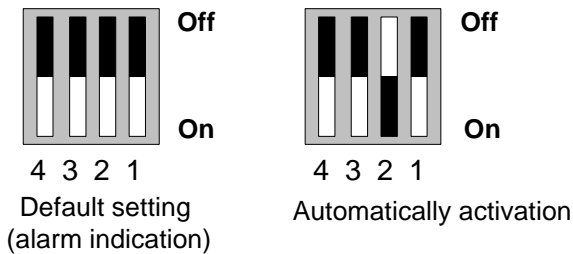

Installation diagram optional Manual Discharge

One-line diagram

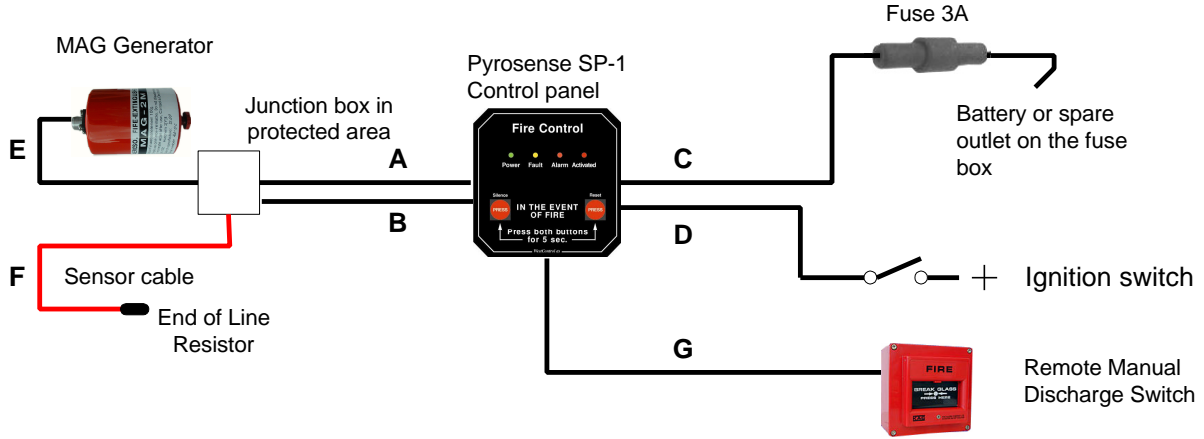

Cabel references

- A - Connection of the MAG Generator to the PyroSense SP-1 Control Panel. Item No. HUS506492
- B - Connection of the Thermal sensing Cable to the PyroSense SP-1 Control Panel. Item No. HUS506492
- C - Connection of the battery to the PyroSense SP-1 Control Panel (2x1mm² stranded).
- D - Connection of the Ignition/Main Power to the PyroSense SP-1 Control Panel (1x0,75mm²)
- E - MAG Generator Flying Lead from the Junction Box to the MAG
- F - Thermal Sensing cable c/w EOL resistor (length 4metres).
- G - Remote Manual Discharge cable. Item No. HUS506492

Installation diagram - Remote Manual discharge Switch

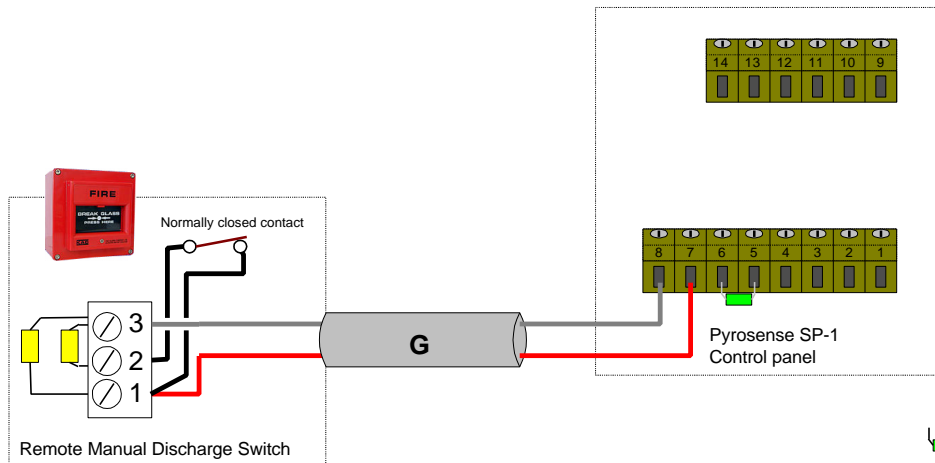

This diagram gives a basic representation of the installation of a Remote Manual Activation Switch.

For Complete Installation see the "Basic Kit" Sheet



Keep the EOL resistors and test lamp for future use.

Installation diagram optional Spot detector (smoke/heat)

One-line diagram

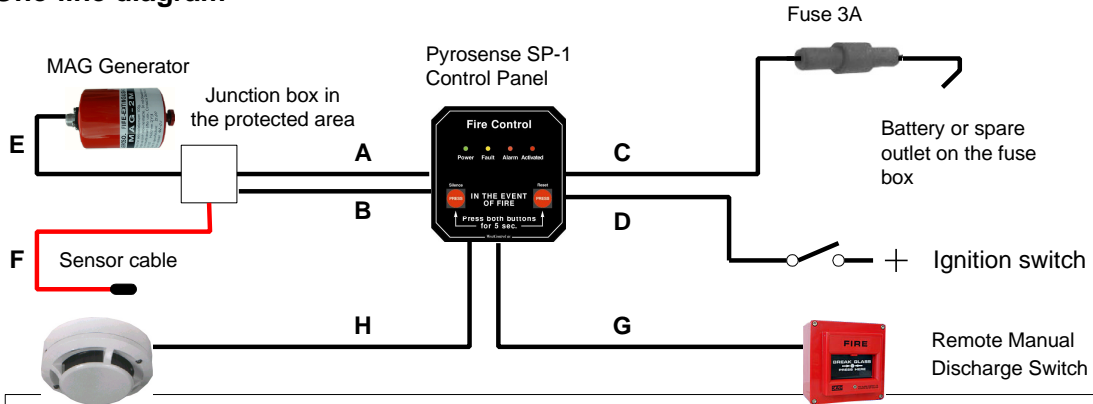

Cable references

- A - Connection of the MAG Generator to the PyroSense SP-1 Control Panel. Item No. HUS506492
- B - Connection of the Thermal sensing Cable to the PyroSense SP-1 Control Panel. Item No. HUS506492
- C - Connection of the battery to the PyroSense SP-1 Control Panel (2x1mm2 stranded).
- D - Connection of the Ignition/Main Power to the PyroSense SP-1 Control Panel (1x0,75mm2)
- E - MAG Generator Flying Lead from the Junction Box to the MAG
- F - Thermal Sensing cable c/w EOL resistor (length 4metres).
- G - Remote Manual Discharge cable. Item No. HUS506492
- H - Detector Cable (4x 0,75mm2)

Installation Diagram - Optional smoke/heat Detector Base (System sensor)

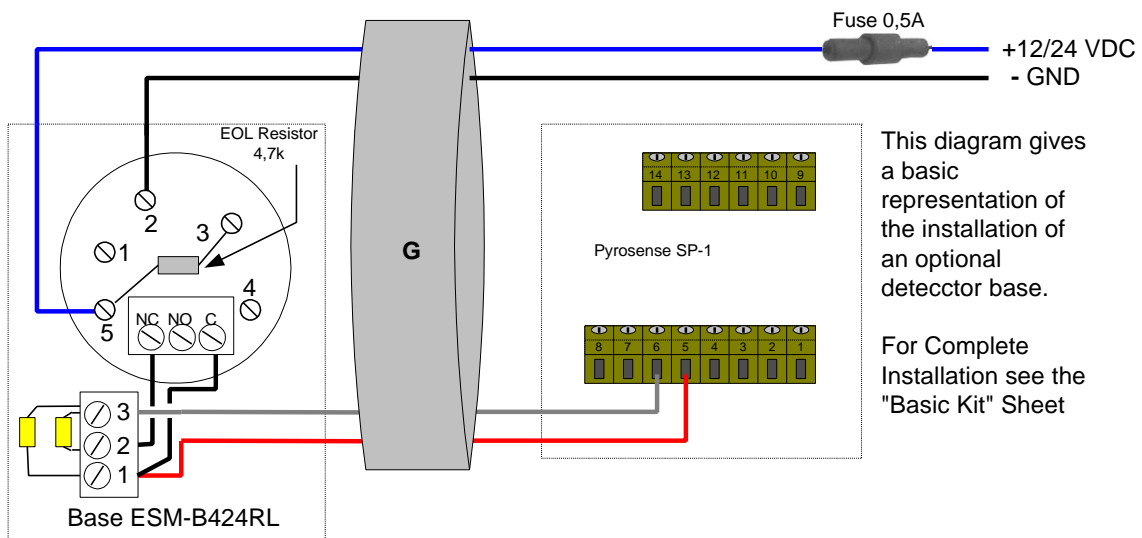

Setting of Dip-switches

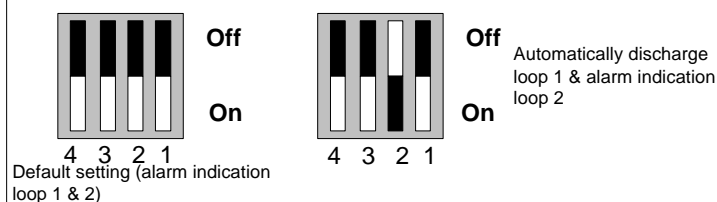

Keep the EOL resistors and test lamp for future use.

Installation diagram optional sounder/Flash beacon

One-line diagram

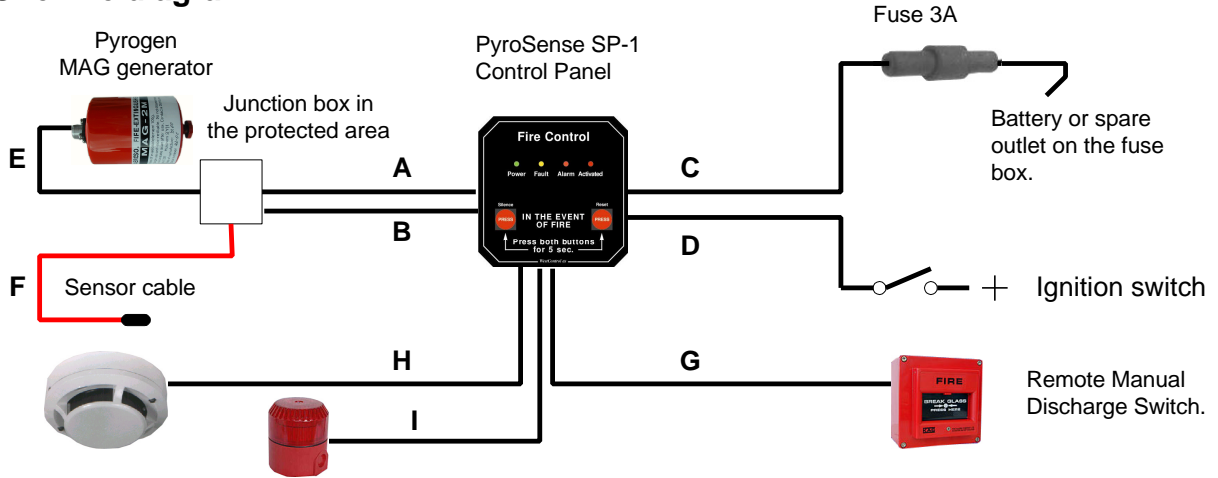

Cabel references

- A - Connection of the MAG Generator to the PyroSense SP-1 Control Panel. Item No. HUS506492
- B - Connection of the Thermal sensing Cable to the PyroSense SP-1 Control Panel. Item No. HUS506492
- C - Connection of the battery to the PyroSense SP-1 Control Panel (2x1mm2 stranded).
- D - Connection of the Ignition/Main Power to the PyroSense SP-1 Control Panel (1x0,75mm2)
- E - MAG Generator Flying Lead from the Junction Box to the MAG
- F - Thermal Sensing cable c/w EOL resistor (length 4metres).
- G - Remote Manual Discharge cable. Item No. HUS506492
- H - Detector Cable (4x 0,75mm2)
- I - Connection of External Sounder/Flash Beacon

Installation Diagram - Optional External Sounder/Flashbeacon

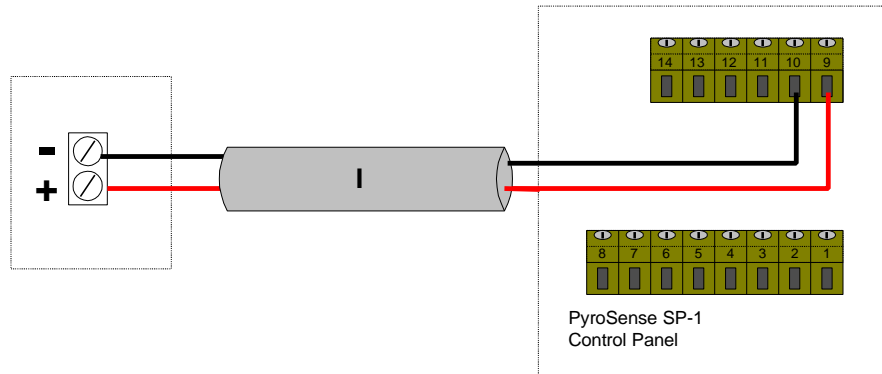

This diagram shows the installation of the optional sounder/flash only.
For Complete Installation see the "Basic Kit" Sheet.

On page 31 & 32 you will find several alternatives of sounders, flash beacons.

Installation Diagram (optional) Relay for Engine stop

Cut + wire from ignition switch and connect the Normally Closed (NC) contact of the Relay in series as shown in the diagram below.

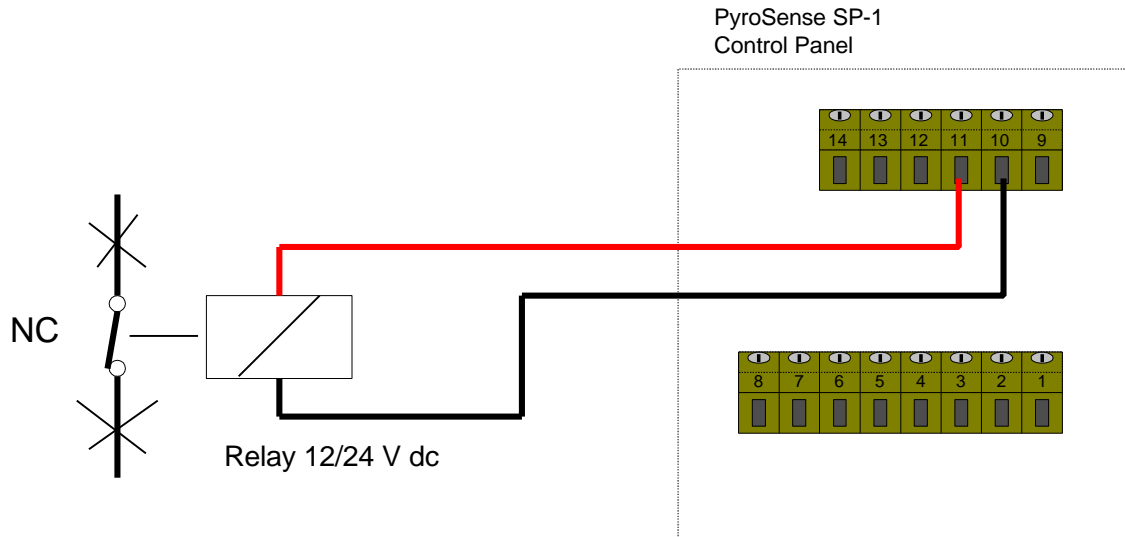

The Normally Open (NO) contact of the Relay is connected in parallel with the Stop button.

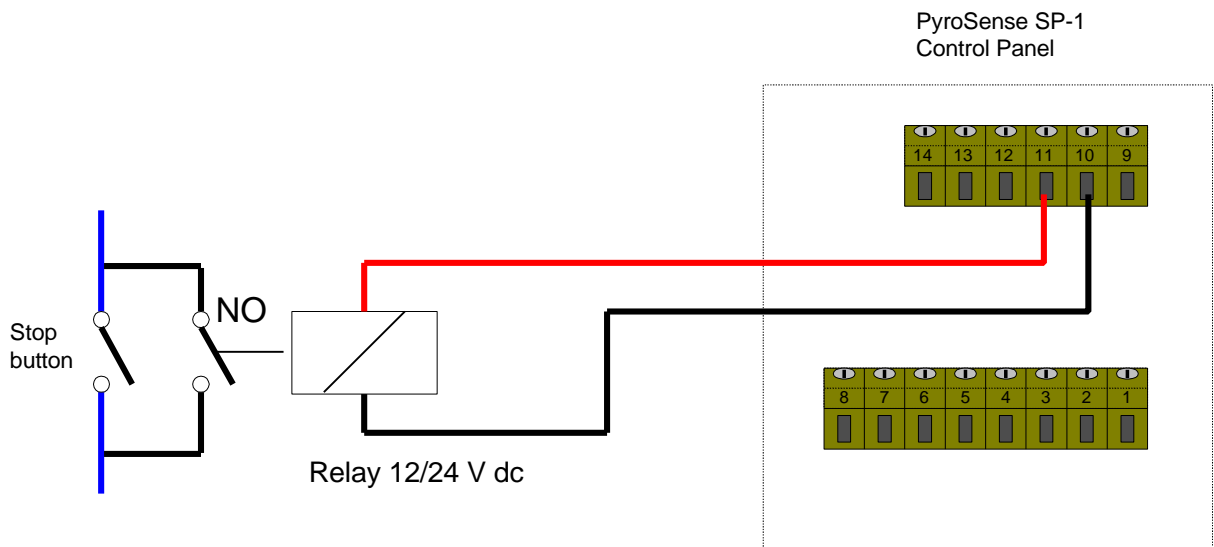

Installation Diagram connection of Alarm Sensors

General connection of Normally Closed (NC) Alarm Contacts to loop 2

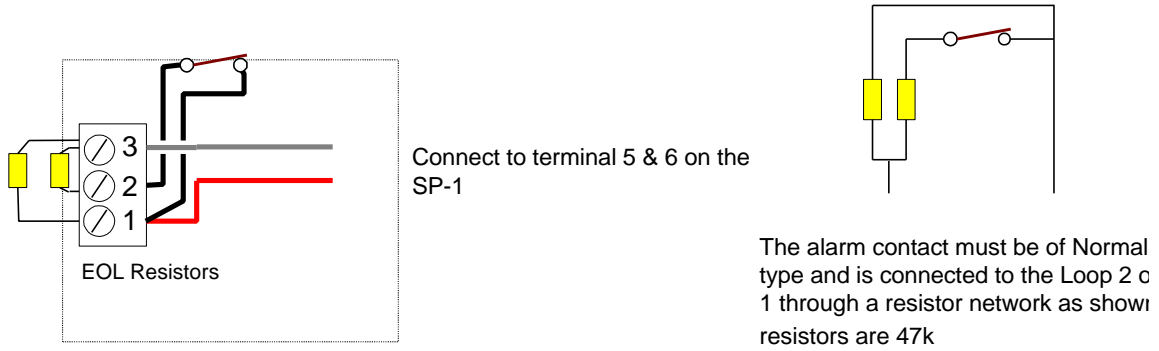

Connection of more than one Alarm Contact to loop 2 of the SP-1

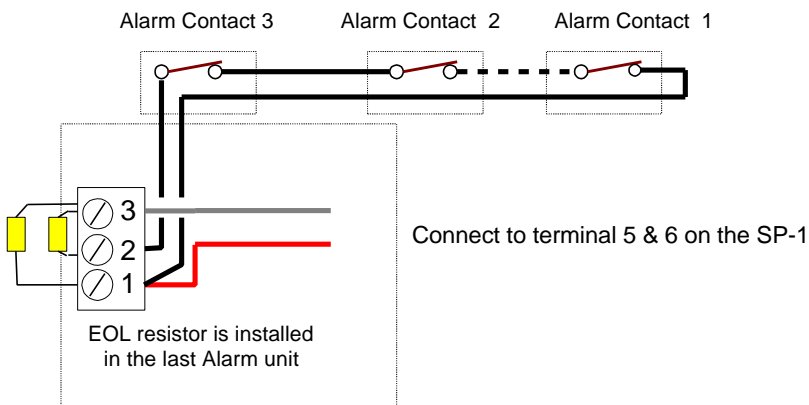

General connection of Normally Open Alarm (NO) Contacts to Loop 1 of the SP-1

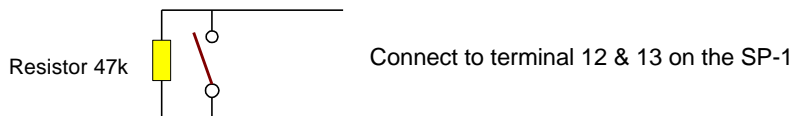

Connection of more than one Alarm Contact to loop 1 of the SP-1

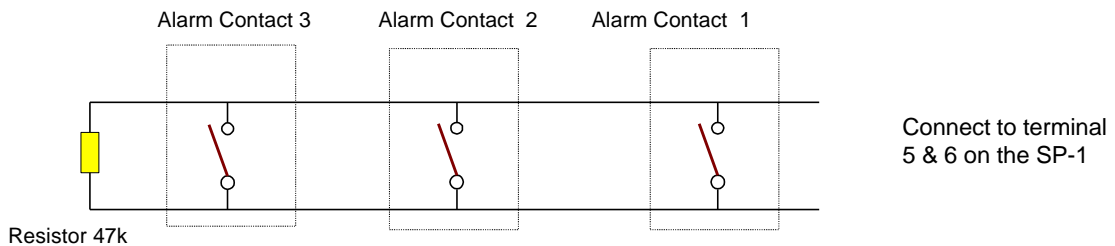

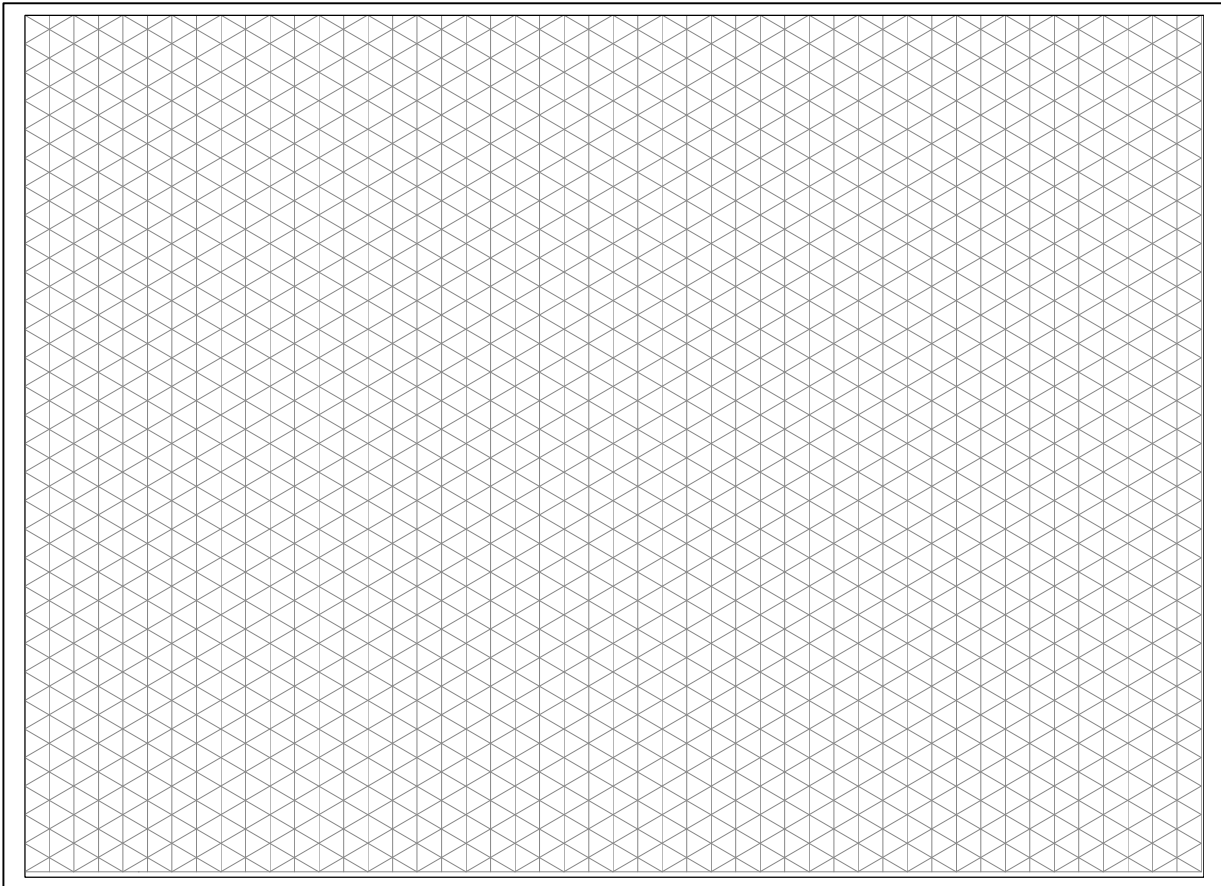
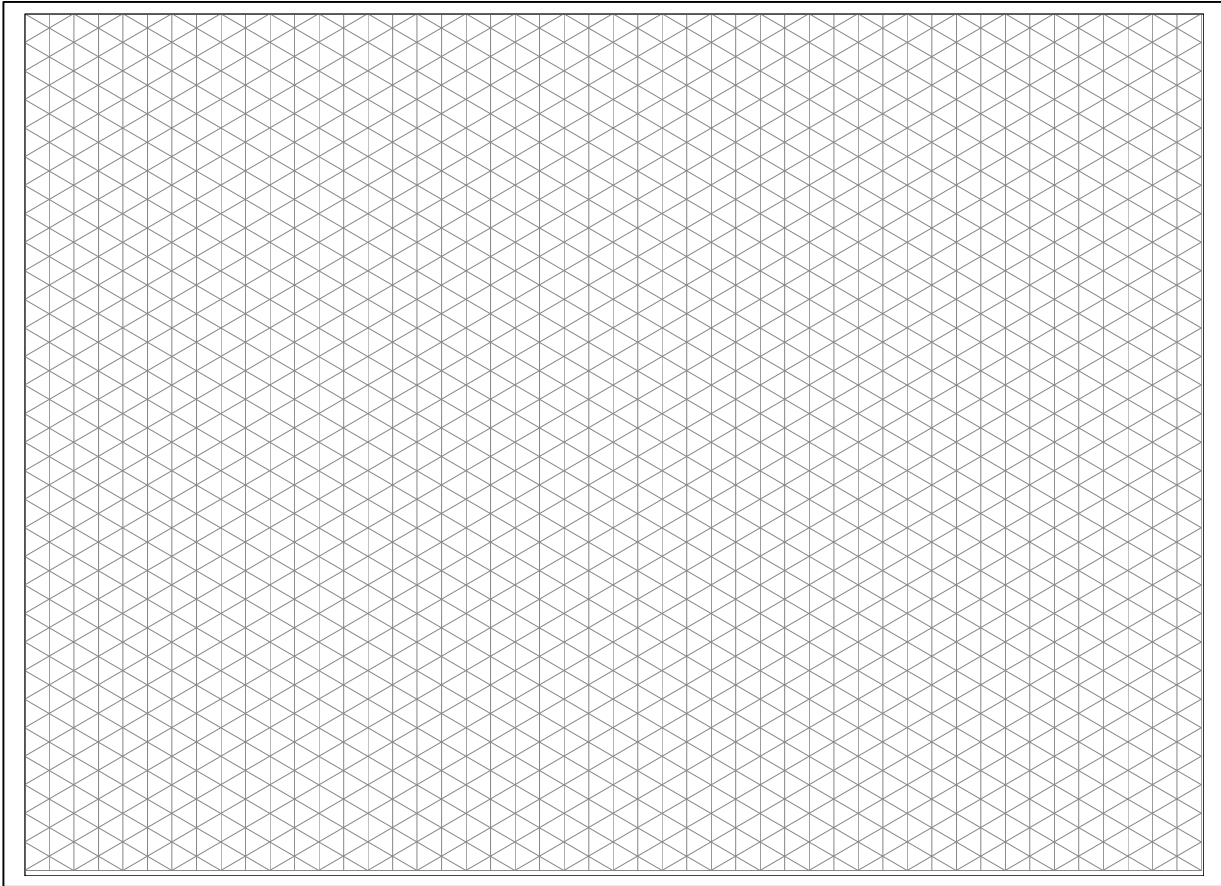

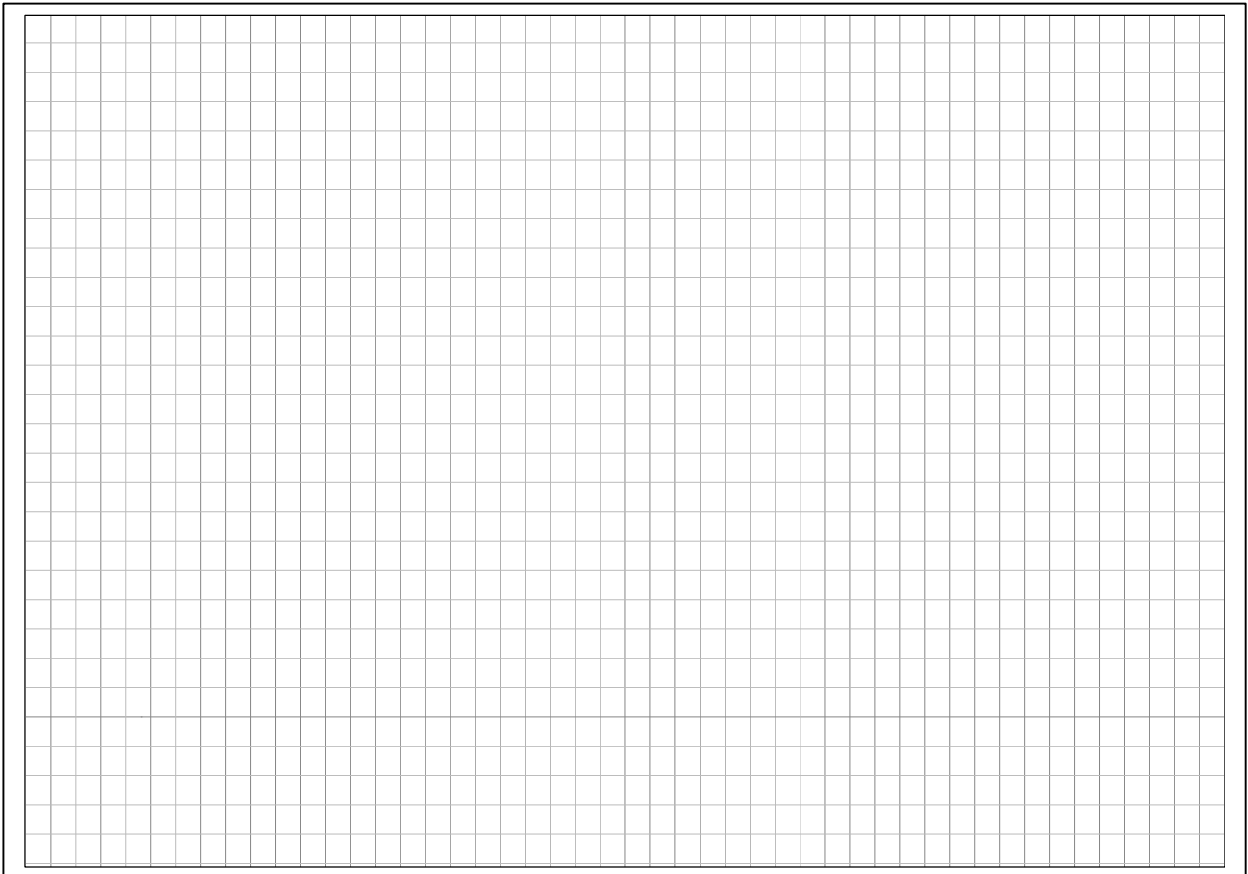
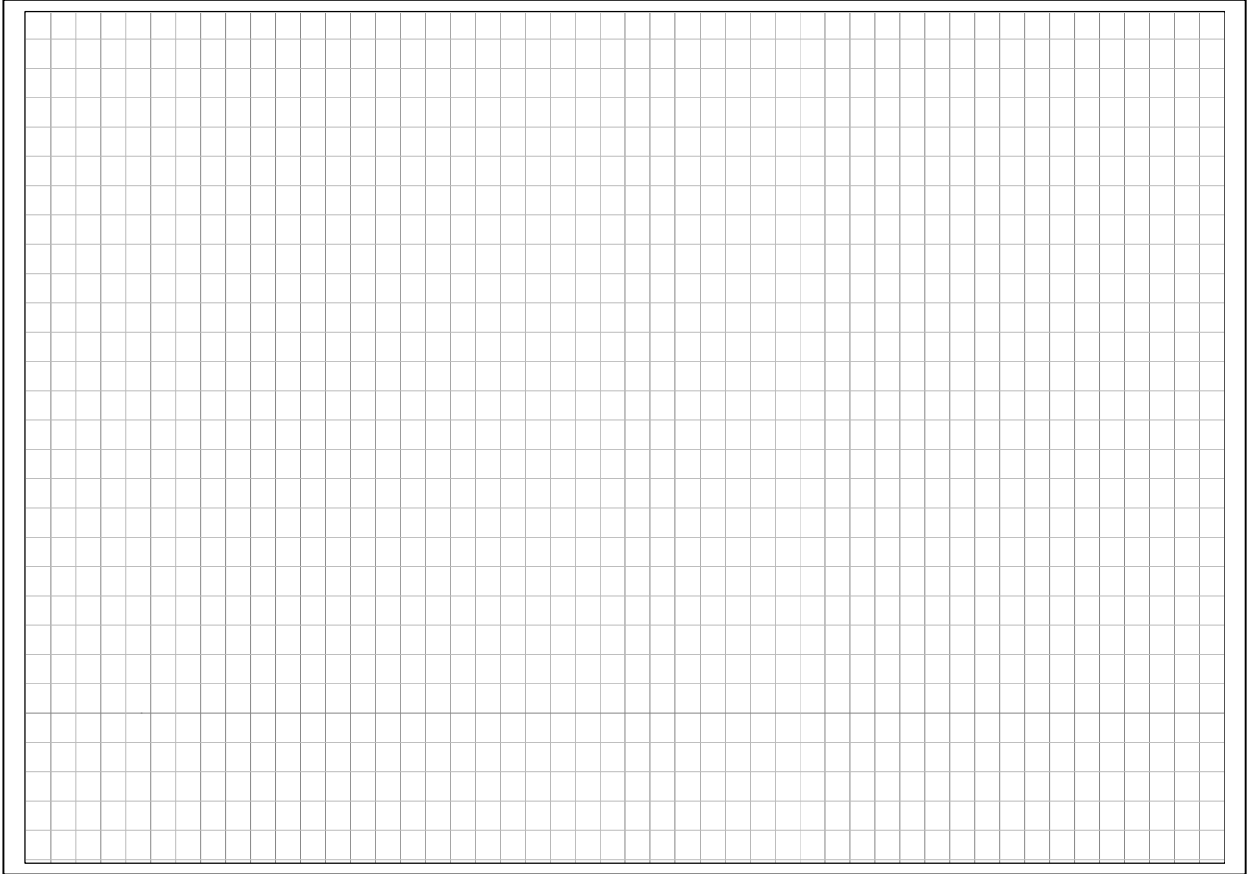



All Products meet the requirements of 89/336/EEC (EMC Directive)

The products described in this publication are subject to availability and may be modified from time to time. Products are provided subject to Pyrogen's respective standard conditions of contract. Nothing in this publication forms any part of any contract.

© Pyrogen Ltd 2000.
Registered Office:
Co Registration No: 3506143
Printed in Norway
Designed & Produced by Technor asa
Further Copies Order No: TEC-DOC-BOAT



Asia Pacific & North America

Pyrogen Ltd.
Gilnow Mill Business Centre
Spa Road,
Bolton U.K.
BL1 4LF
Tele: +44 (0) 1204 373300
Fax: +44 (0) 1204 373355
e.mail pyrogen@btconnect.com
www.pyrogen.com