

Both the Pyrogen Generator & the heat Sensor are terminated back to the FirePak FACP Control Panel, which once a signal is received from the sensor, will activate Alarms/Sounders, Main fire control systems & the Pyrogen Generator.

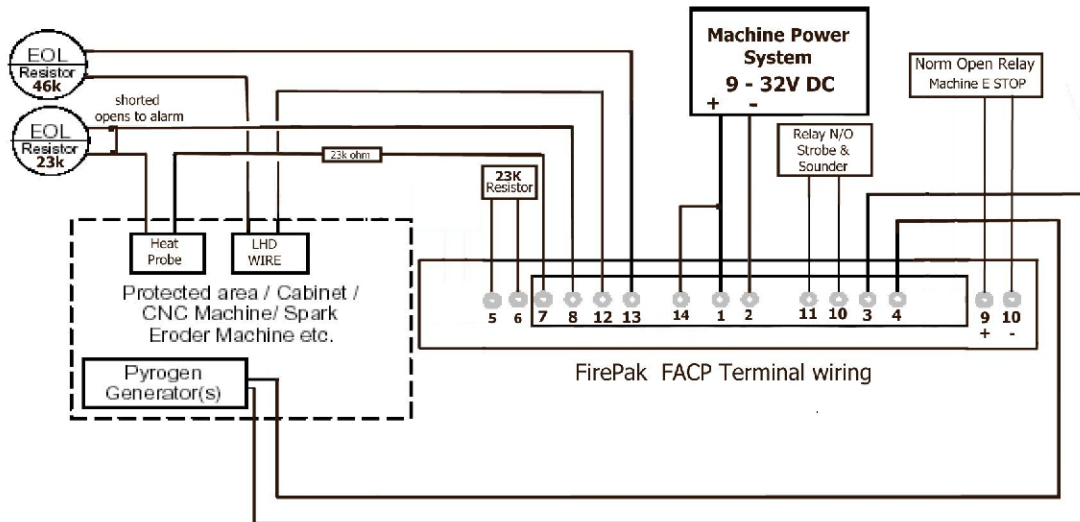

Pyrogen Fire Suppression, LLC  
 11717 Bedford St.  
 Houston, TX 77031  
 P 713 952-1996

Product Name. **PCNC-x-B**  
**CNC/ Spark Eroder Enclosure Protection System**

File Name: FIREPAK FACP

Date: July 5, 2006